



IRT Electronics Pty Ltd A.B.N. 35 000 832 575
26 Hotham Parade, ARTARMON N.S.W. 2064 AUSTRALIA
National: Phone: (02) 9439 3744 Fax: (02) 9439 7439
International: +61 2 9439 3744 +61 2 9439 7439
Email: sales@irtelectronics.com
Web: www.irtelectronics.com

IRT 1RU Type

AMS-1000 10 x 1 Video & Audio Passive Switcher

Designed and manufactured in Australia

**IRT can be found on the Internet at:
<http://www.irtelectronics.com>**

AMS-1000

10 x 1 Video & Audio Passive Switcher

Instruction Manual

Table of Contents

Section	Page
Operational safety	2
General Description	3
Applications	3
Technical Specifications	4
Circuit Description	5
Installation	6
Front & rear panel connector diagrams	7
Maintenance & storage	8
Warranty and service	8
Equipment return	8
Drawing index	9

Operational Safety:

WARNING

Operation of electronic equipment involves the use of voltages and currents that may be dangerous to human life. Note that under certain conditions dangerous potentials may exist in some circuits when power controls are in the **OFF** position. Maintenance personnel should observe all safety regulations.

Do not make any adjustments inside equipment with power **ON** unless proper precautions are observed. All internal adjustments should only be made by suitably qualified personnel. All operational adjustments are available externally without the need for removing covers or use of extender cards.

General Description

The AMS-1000 is a passive 10 x 1 video and audio switcher intended for use in non-critical switching and monitoring applications.

Inputs are selected by switches, which are mechanically interlocked. A white flag indicator clearly shows the selected switch from a distance without the need for power.

Video: All non-selected video sources are terminated in 75 Ω . The selected video input is switched through to the output and must be terminated at the destination.

Audio: The audio consists of two identical circuits for each switch position. These may be designated as a pair for balanced operation or as Left and Right channels for unbalanced stereo operation.

All audio lines are loaded with 10 K Ω at the input. The selected pair is connected to the output connector and the total loading will be that of the destination in parallel with the switcher loading.

The switcher is housed in an IRT one rack unit (480 x 230 x 44 mm), 19" rack mounting chassis with video connections via BNC connectors and audio via plug-in terminal blocks.

Applications

- **Monitoring of slave machines in dubbing suites.**
- **Patchbay replacement.**

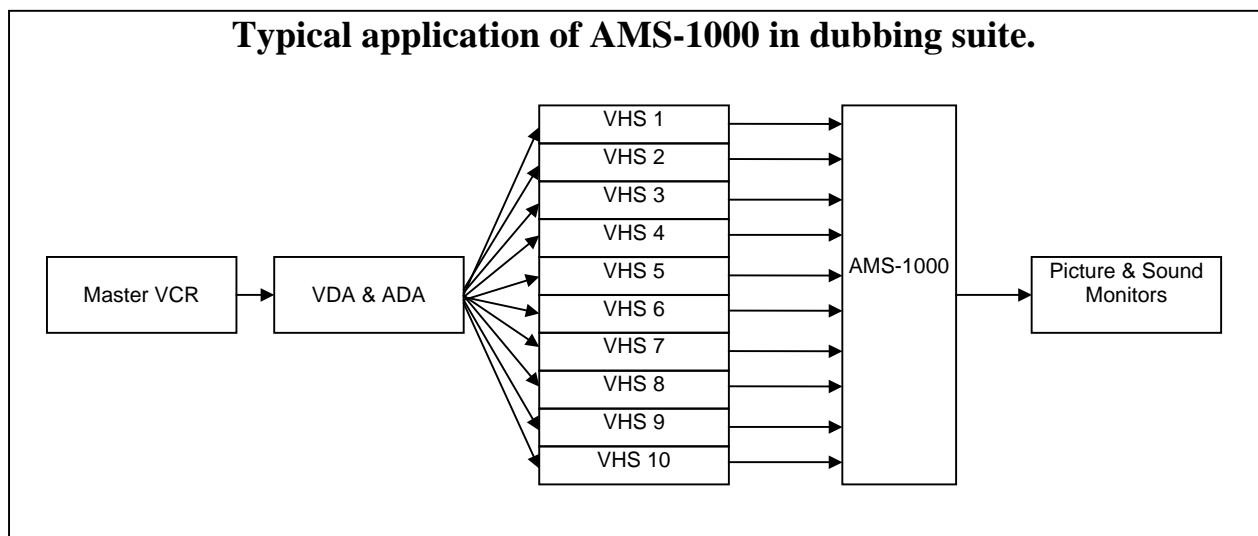

Technical Specifications

AMS-1000

Video inputs:

Number 10
Type 75 Ω terminated when not selected
Terminated by output load when selected.

Video output:

Number 1
Type Directly connected to selected input
Open circuit if no input selected

Audio inputs:

Number 10 x 2
Type 10 K Ω terminated when not selected
Impedance determined by load when selected.
May be wired as balanced pairs or as stereo unbalanced pairs

Audio output:

Number 1
Type Directly connected to selected input
Open circuit if no input selected

Connectors:

Video BNC
Audio Phoenix plug-in screw blocks

Other:

Power Requirements Nil – totally passive
Mechanical Suitable for mounting in standard 19" rack, with input and output connections on the rear panel.
Finish: Grey enamel, silk-screened black lettering & red IRT logo.
Dimensions 480 x 230 x 44 mm
Standard accessories (supplied with module) Matching audio connectors

Due to our policy of continuing development, these specifications are subject to change without notice.

Circuit Description

AMS-1000:

The input of the AMS-1000 is comprised of 10 BNC connector type video inputs and 10 balanced line inputs (these may also be configured to 10 stereo unbalanced inputs.)

The video inputs are terminated in 75Ω when not selected, when selected the video input is terminated by the output load.

The audio inputs are switched through the same bank of switches as the video inputs. These consist of 2 identical circuits for each position. Each audio line input is terminated with a $10\text{ K}\Omega$ resistor to ground. When selected the input is terminated with it's $10\text{K}\Omega$ resistor in parallel with the output load.

Installation

Handling:

The AMS-1000 has no specific handling requirements

When individual modules are stored no specific storage requirements are recommended.

Power:

The AMS-1000 being totally passive has no power requirements.

Earthing:

There is no earth system built into the AMS-1000. This is being due to the unit not having any active components installed.

For shielding reasons the AMS-1000 should be earthed to the rack the unit has been installed in. If the AMS-1000 has not been installed into a racking system a technical earth should be attached to the chassis to help with shielding considerations

Installation:

The AMS-1000 is a 1 RU box that slots straight into your standard racking system. There are no adjustments to be made to this unit.

Once you have installed the unit into your rack, connect the cables to the appropriate connectors.

Audio Connections:

The AMS-1000 can handle either Unbalanced Stereo or Balanced Mono Audio connections. The appropriate wiring configurations can be found in the diagrams below.

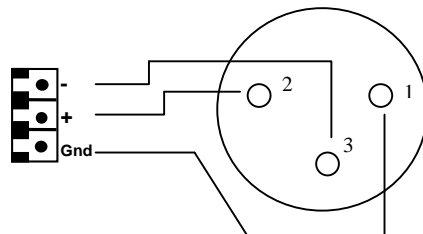

Balanced line → XLR Connector

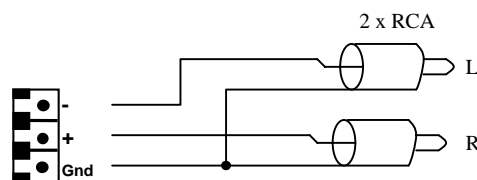

Unbalanced Stereo → RCA Connectors

Front & rear panel connector diagrams

The following front panel and rear assembly drawings are not to scale and are intended to show relative positions of connectors, indicators and controls only.

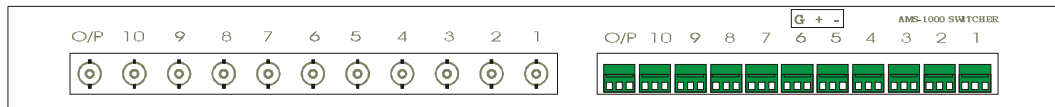
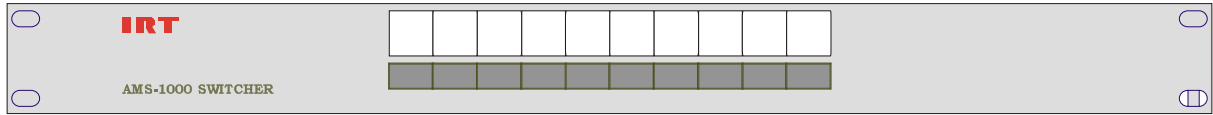

Maintenance & Storage

Maintenance:

No regular maintenance is required.

Care however should be taken to ensure that all connectors are kept clean and free from contamination of any kind. This is especially important in fibre optic equipment where cleanliness of optical connections is critical to performance.

Storage:

If the equipment is not to be used for an extended period, it is recommended the whole unit be placed in a sealed plastic bag to prevent dust contamination. In areas of high humidity a suitably sized bag of silica gel should be included to deter corrosion.

Where individual circuit cards are stored, they should be placed in antistatic bags. Proper antistatic procedures should be followed when inserting or removing cards from these bags.

Warranty & Service

Equipment is covered by a limited warranty period of three years from date of first delivery unless contrary conditions apply under a particular contract of supply. For situations when “**No Fault Found**” for repairs, a minimum charge of 1 hour’s labour, at IRT’s current labour charge rate, will apply, whether the equipment is within the warranty period or not.

Equipment warranty is limited to faults attributable to defects in original design or manufacture. Warranty on components shall be extended by IRT only to the extent obtainable from the component supplier.

Equipment return:

Before arranging service, ensure that the fault is in the unit to be serviced and not in associated equipment. If possible, confirm this by substitution.

Before returning equipment contact should be made with IRT or your local agent to determine whether the equipment can be serviced in the field or should be returned for repair.

The equipment should be properly packed for return observing antistatic procedures.

The following information should accompany the unit to be returned:

1. A fault report should be included indicating the nature of the fault
2. The operating conditions under which the fault initially occurred.
3. Any additional information, which may be of assistance in fault location and remedy.
4. A contact name and telephone and fax numbers.
5. Details of payment method for items not covered by warranty.
6. Full return address.
7. For situations when “**No Fault Found**” for repairs, a minimum charge of 1 hour’s labour will apply, whether the equipment is within the warranty period or not. Contact IRT for current hourly rate.

Please note that all freight charges are the responsibility of the customer.

The equipment should be returned **to the agent who originally supplied the equipment** or, where this is not possible, to IRT direct as follows.

Equipment Service
IRT Electronics Pty Ltd
26 Hotham Parade
ARTARMON
N.S.W. 2064
AUSTRALIA

Phone: 61 2 9439 3744
Email: service@irtelelectronics.com

Fax: 61 2 9439 7439

Drawing Index

Drawing #	Sheet #	Description
802327	1	AMS-1000 10 x 1 Video / Audio Switcher.

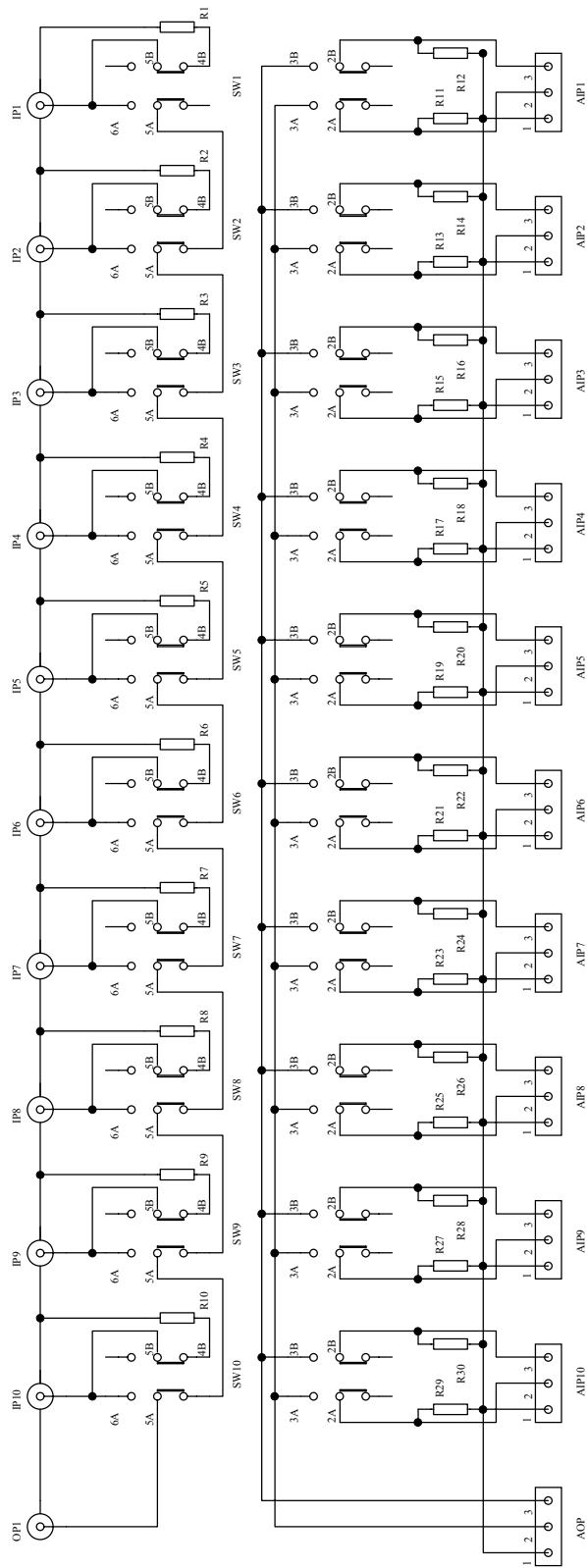

IRT	
SIZE	AMS-1000
TITLE	10x1 VIDEO/AUDIO SWITCHER
DRAWN	RBB
CHECKED	
ENG.APP	
SCALE	
DRAWING No.	80237
SHEET	1 OF 1
IRT Electronics Pty. Ltd. ACTARMOON NSW AUSTRALIA 2164	

1 17/03/95
ECR1251
2 20/09/01