



I R T Electronics Pty Ltd A.B.N. 35 000 832 575
26 Hotham Parade, ARTARMON N.S.W. 2064 AUSTRALIA
National: Phone: (02) 9439 3744 Fax: (02) 9439 7439
International: +61 2 9439 3744 +61 2 9439 7439
Email: sales@irtelectronics.com
Web: www.irtelectronics.com

IRT 1RU AC Chassis Frame for Eurocards

Type FRU-1034

CDM-1000

SMU-4000

Designed and manufactured in Australia

**IRT can be found on the Internet at:
<http://www.irtelectronics.com>**

IRT 1RU AC Chassis Frame for Eurocards

Type FRU-1034

CDM-1000

SMU-4000

Instruction Book

Table of Contents

Section	Page
Revision History	2
Operational Safety	4
FRU-1034 IRT 1RU AC Chassis Frame for Eurocards	5
FRU-1034 General Description	5
FRU-1034 Technical Specifications	6
FRU-1034 Configuration	7
FRU-1034 Installation of Modules	8
Eurocard Module	8
EMC	9
Power connections for use with older style rear assemblies	10
Front, Rear & Top panel diagrams	12
CDM-1000 SNMP Agent Frame Controller	13
CDM-1000 General Description	13
CDM-1000 Technical Specifications	14
CDM-1000 Installation	15
CDM-1000 Front panel connector diagram	15
CDM-1000 Setup	16
SMU-4000 SNMP Plug-in Management Controller	18
SMU-4000 General Description	18
SMU-4000 Installation	19
Figure 1: SMU-4000 module	19
SNMP – What Is It?	20
Warranty & Service	22
Equipment return	22

This instruction book applies to units later than S/N: 0801001.

Operational Safety:

WARNING

Operation of electronic equipment involves the use of voltages and currents that may be dangerous to human life. Note that under certain conditions dangerous potentials may exist in some circuits when power controls are in the **OFF** position. Maintenance personnel should observe all safety regulations.

Do not make any adjustments inside equipment with power **ON** unless proper precautions are observed. All internal adjustments should only be made by suitably qualified personnel. All operational adjustments are available externally without the need for removing covers or use of extender cards.

WARNING

AC Power Supplies

Whilst every effort has been made to prevent exposure of service personnel to dangerous voltages, AC mains input power supplies are by their nature dangerous when connected to the AC mains supply.

Wherever possible maintenance work on power supplies should be carried out with the mains input disconnected - NOT just switched off.

When testing units with the mains supply ON, the supply should be connected through an earth leakage circuit breaker and should not be done without another person in attendance.

IRT 1RU AC Chassis Frame for Eurocards

Type FRU-1034

General Description

The grouping of products with a common frame and mains power supply benefits the user by providing economy and minimum utilisation of valuable space.

Different modules, including digital and analogue, may be mixed in the one frame to provide a compact solution to system design and ease of later expansion.

The FRU-1034 is a 1RU frame that covers the requirements of small applications where only one or two IRT Eurocard modules are required. For larger applications requiring up to ten or twelve Eurocards, or requiring redundant power supplies, see separate handbook on IRT's 3RU frame option.

The FRU-1034 provides guide rails to provide a true Eurocard frame for easy maintenance. A single power supply is included with a switchable AC input voltage.

Provision is also made for a separate Simple Network Management Protocol (SNMP) controller board to be installed separately to the allowable two Eurocard modules, with Ethernet controls available via the rear, for use with IRT Eurocards that are SNMP capable.

The FRU-1034 is suitable for IRT's current range of Eurocards¹ and comes standard with a front and rear blanking plate for situations where only one Eurocard is used.

IRT Eurocards and 1 RU frame have neutral grey colour front panels providing both an aesthetic appeal and correct colour background for use close to monitors.

Standard features:

- **Built in power supply.**
- **Suit IRT's current 700, 3000 and 4000 series Eurocards.**
- **Take up to two Eurocard modules.**
- **Optional plug in Simple Network Management Protocol (SNMP) card.**

¹ Older IRT 700 and 3000 series Eurocards sold prior to 2006 require an extra internal power cable to be added in order to work correctly in this frame. All 4000 series Eurocard modules are fully compatible.

Technical Specifications

IRT Eurocard frame Type FRU-1034

Power requirements:

Voltage		115 or 230 Vac \pm 10%, switch selectable
Frequency		45 Hz - 65 Hz
Power		32.2 VA maximum
Fusing	230 Vac (220-240 Vac)	250 mA anti-surge
	115 Vac (110-130 Vac)	500 mA anti-surge

Output:

28 Vac centre tapped (14 - 0 - 14) loaded.
24 VA maximum

Connectors:

AC power input IEC 320 with integral fuseholder.

Other:

Temperature range 0 - 50° C ambient

Mechanical 1 RU (482 mm x 44.5 mm) standard 19" rack frame
Suitable for mounting in standard 19" racks

Dimensions 482 x 44.5 x 238 mm (frame empty.)
Clearance width 442 mm

Finish: Front Panel Grey background, black lettering and red IRT label.
Body & rear panel Aluminium with silk screened black lettering.

Standard accessories IEC power lead.

Optional Accessories: CDM-1000 Simple Network Management Protocol (SNMP) controller card for use with 4000 series Eurocards fitted with SNMP capability.
Internal power cable for older style rear assembly compatibility.

Due to our policy of continuing development, these specifications are subject to change without notice.

Configuration

The transformer has two primary windings allowing configuration for the locally available mains input voltage. A voltage selector switch is accessible through a rectangular hole in the top of the frame. Using a flat bladed screwdriver switch the voltage selector switch to either the 115 or 230 switch position. The 115-switch position, besides being for a 115 Vac input voltage, is suitable for use with 110 Vac or 130 Vac input voltages. The 230-switch position, besides being for a 230 Vac input voltage, is also suitable for use with 220 Vac or 240 Vac. Be sure that power is not connected before changing the voltage selector switch.

Two fuses are supplied for each of the two main voltage ranges. One is used as the operating fuse. The other is spare and should be installed in the place provided inside the IEC input connector.

Generally the FRU-1034 is supplied in the 230-switch position with 250mA anti-surge fuses installed. Fuses for the 115-switch position setting are supplied with 500mA anti-surge fuses in a small plastic bag labelled 110 Vac fuses connected to the rear of the chassis. However the voltage selector switch setting position should be checked when the unit is received before applying power to the unit.

Before connecting power check that the voltage selector is in the correct position and that the correct rating fuse has been installed in the IEC connector fuse holder.

Operation on input voltages not matching the selected voltage may result in damage to the unit and any installed modules.

Always change the fuse when changing selection of input voltage.

Installation of Modules

CDM-1000 SNMP Agent Module

See CDM-1000 installation section of this manual.

Eurocard Module

In order for an IRT Eurocard to be mounted within the FRU-1034 frame, the rear assembly must be fitted with power pins (10-pin) to pick up power from the frame power bus. All IRT 4000 series cards come fitted with these pins and are fully compatible with the FRU-1034 frame as are current 700 and 3000 series Eurocard modules that have the correct type of power connector on the rear assembly. Older versions of 700 and 3000 series Eurocard modules that do not have the power pins on the rear assembly need an additional internal power cable added to connect up to the 3-pin power connector common to all IRT Eurocard modules.

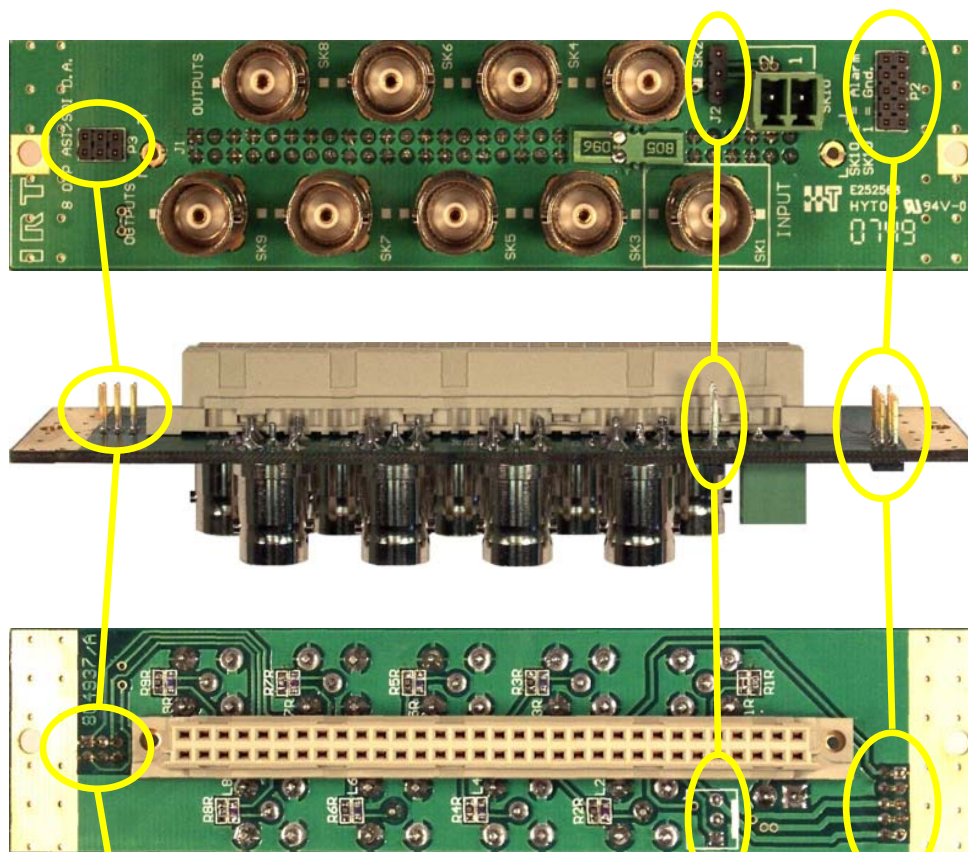

SNMP Pins (6 pin) for FRU-1034 and 4000 series frames.

Power Pins (3-pin) for older style 1RU frame.

Power Pins (10-pin) for FRU-1034 and 4000 series frames.

Typical 4000 series Eurocard rear assembly showing locations of power and SNMP pins.

Ensure that the rear assembly has the correct orientation and carefully align the power pins and SNMP pins over power and SNMP bus connectors. With equal pressure, press until the rear assembly PCB touches the frame. Install the two retaining screws (Metric M2.5 x 6 mm).

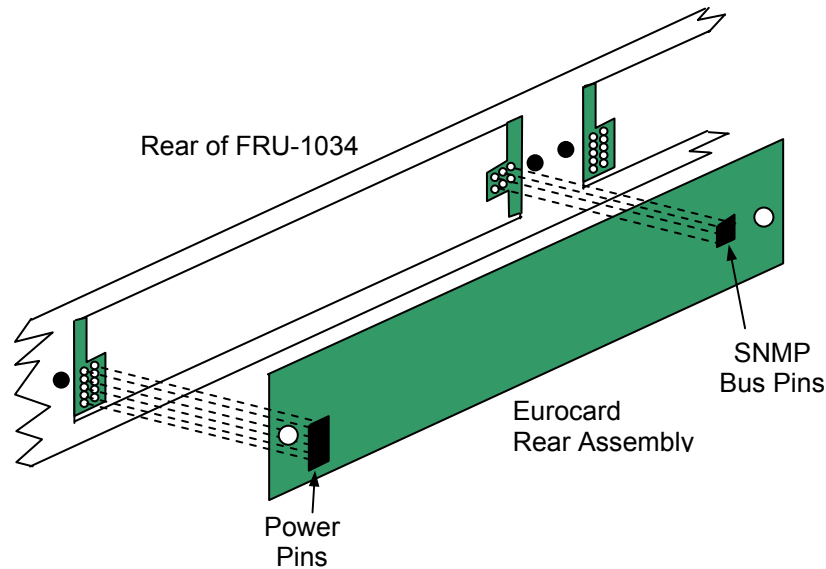

Rear assemblies may be removed for maintenance. Make sure that extraction force is applied equally and steadily at the top and bottom of the rear assembly simultaneously.

If extraction force is not equally applied, there is a good chance that the module connector pins will be bent, making it very difficult to re-install the rear assembly.

Slide the Eurocard module into the front of the frame in the guides corresponding to the position of the installed mating rear assembly until it makes mating contact with the rear assembly 64 pin connector, then tighten the two front retaining screws.

Warning

Optical Connections

The optical connectors on modules may be attached to the main module PCB, NOT the rear connector assembly.

When installing the optical fibre sufficient slack should be allowed for the module to be withdrawn with the optical fibre attached until the connector is clear of the frame and can be disconnected.

If this is not done, the module will not be able to be removed without first disconnecting the optical fibre at the rear. Attempting to remove the module without first disconnecting the fibre may result in damage to the fibre and / or the module.

EMC

Due to EMC (electromagnetic compliance) standards, IRT recommends that all unused card positions be closed off using IRT front blanking panels, on the front, and rear blanking panels, on the rear, of the frame.

Power connections for use with older style rear assemblies

For fitting an early version rear assembly that does not have the 10-pin power pin connector to the FRU-1034 an additional cable needs to be added internally to the FRU-1034. Fit a 3-conductor cable terminated with 3-pin Molex type 0.1 inch plugs to position A (shown below). The other end fits to the 3-pin power connector on the rear assembly.

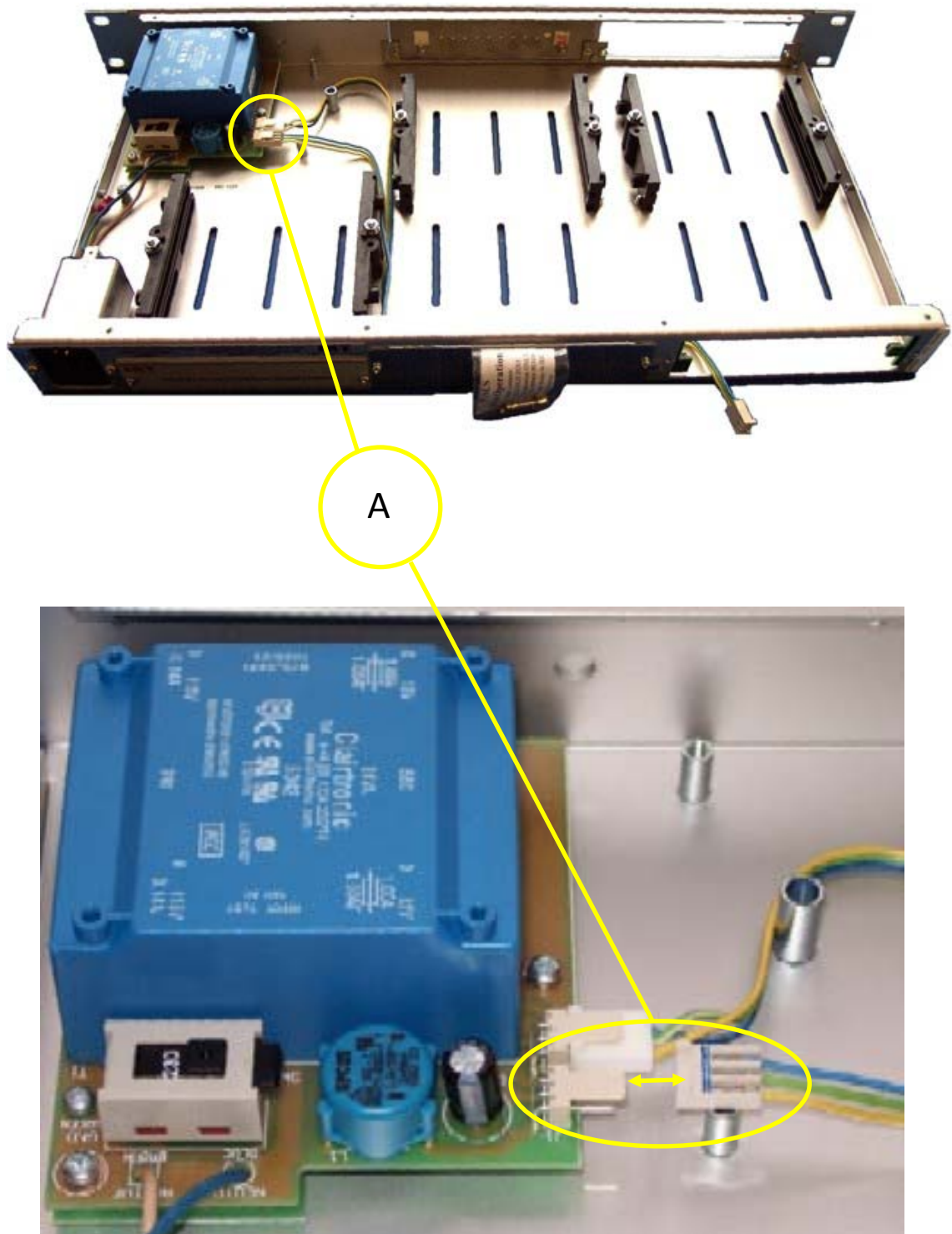

Plug B (shown below) supplies power to the rear motherboard for supplying power to 4000 type (or equivalent) rear assemblies. If a second older version (non 4000 series or equivalent) rear assembly needs to be fitted, remove plug B (shown below) and connect to the 3-pin power connector on the second rear assembly.

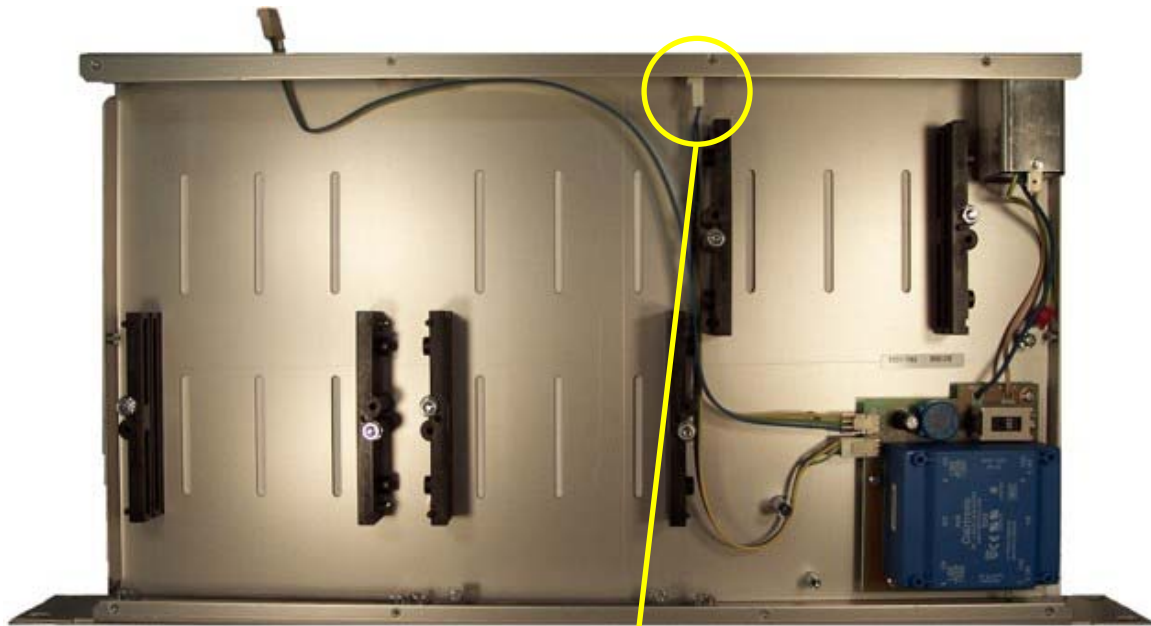

B

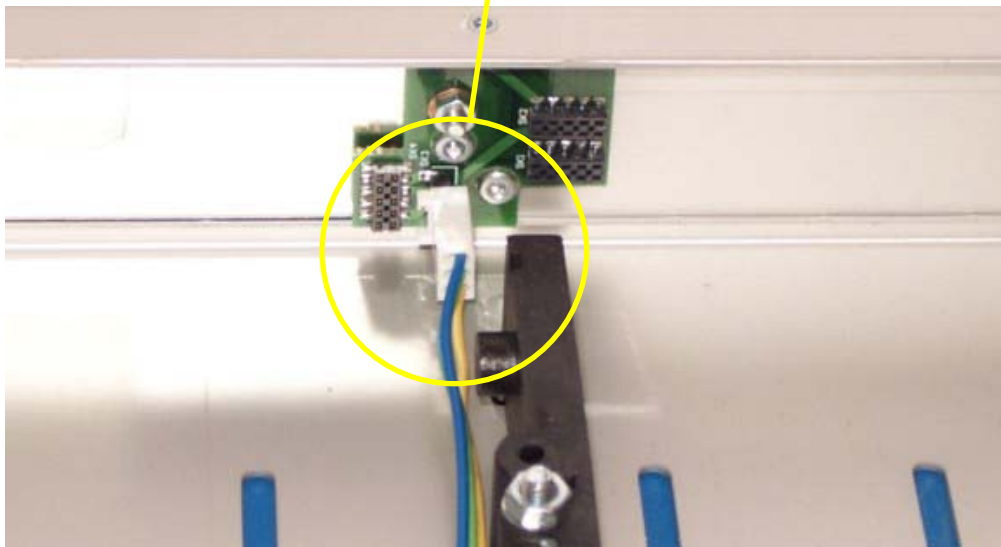

Front, Rear & Top panel diagrams:

The following front, rear and top panel diagrams are intended to show relative positions of controls and modules and are not to scale.

Front view:

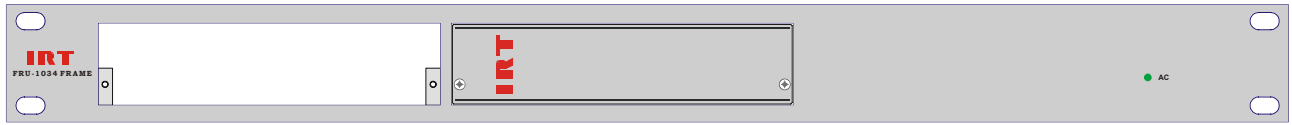

Rear view:

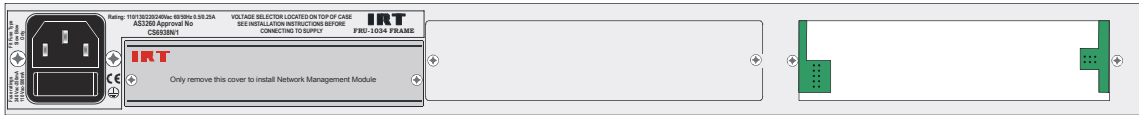

Top View:

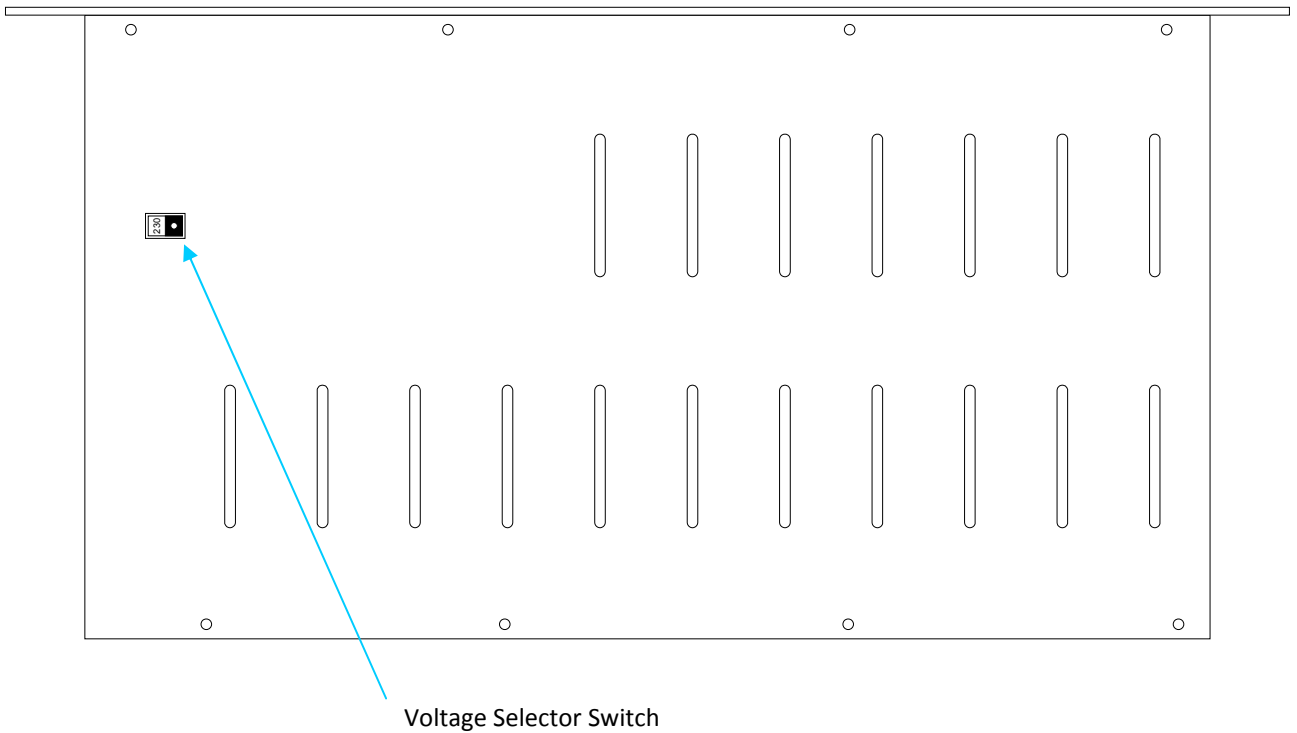

SNMP Agent Frame Controller Type CDM-1000

General Description

The CDM-1000 is a Simple Network Management Protocol (SNMP) Agent for use in IRT's FRU-1034 1RU frame. It occupies its own designated slot in the rear of the frame, next to the power input socket, so it does not affect the number of modules that can be used within the frame.

The CDM-1000 can communicate with all modules in an FRU-1034 frame that are fitted with an SMU-4000 SNMP Interface sub-board, or have inbuilt SNMP facilities. The information obtained is forwarded via an Ethernet connection to any SNMP Network Management System (NMS) whose address is configured in the CDM-1000.

The CDM-1000 holds parameters such as Frame Name, Address and Location. This information may be set via an RS232 Configuration port.

The NMS third party software (not supplied by IRT) polls the CDM-1000 to remotely monitor and control the frame and its SNMP capable modules.

In the event of a major alarm from any of the modules an alarm condition, known as a Trap, is automatically sent without any prompting from the NMS.

A relay output indicates loss of power to the frame that it is plugged into.

Ethernet connection is via an RJ45 connector and the RS232 is via a D9 female connector on the rear of the frame. Modules that are being monitored and controlled share a common data bus on the frame.

SNMP monitoring and control finds particular use in remote or unmanned locations such as transmitter sites, or where control via a computer is desired.

As the CDM-1000 can be assigned its own IP Address, multiple sites can be monitored and controlled via the one NMS. Alternatively, multiple NMS's in different locations can be used to monitor and control the same site.

Features:

- **SNMP remote monitoring and control via Ethernet connection**
- **Automatic "Trap" transmission on major alarms**
- **Own designated slot in the FRU-1034 1RU frame**

CDM-1000 Technical Specifications

Ethernet:

Rate 100baseT\ 10 baseT.
Connector RJ45

RS232:

Rate 9600 baud
Connector Female D9

SNMP:

Version 1
Configurable settings sysContact
sysName
sysLocation
Agent IP address
NMS IP address (max 5)
Gateway IP address
Subnet mask
Community
Agent port number
Trap port number

Power Requirements 28 Vac CT (14-0-14) or ± 16 Vdc.

Power consumption <5 VA.

Other:

Temperature range 0 - 50° C ambient.

Mechanical Suitable for mounting in IRT 1RU 19" rack chassis with SNMP capability.

Due to our policy of continuing development, these specifications are subject to change without notice.

CDM-1000 Installation

If the FRU-1034 frame is to be fitted with SNMP capability, then the CDM-1000 SNMP Agent module needs to be installed.

Viewed from the rear, the CDM-1000 occupies its own designated spot to the left of the FRU-1034 frame. Remove the existing blanking panel, next to the power inlet connector, from the frame and slide the CDM-1000 into position being sure that the 10-pin connectors fully mate with the connectors on the frame. Secure with fitted mounting screws.

Signal connections to this card are via the exposed panel of the CDM-1000 rear of the frame. The 9 pin female D9 connector is an RS-232 interface for connection to a computer for initial setup parameters of the frame for SNMP use. The RJ45 connector is for Ethernet connection.

Alarm Output:

In the event of a power failure to the frame a normally closed (N/C) to ground relay contact acts as an alarm via the 3-pin phoenix connector located next to the Ethernet connector. Whilst there is power to the board the alarm connector is open circuit.

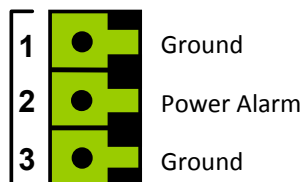

Front panel connector diagram

The following front panel drawing is not to scale and are intended to show relative positions of connectors, indicators and controls only.

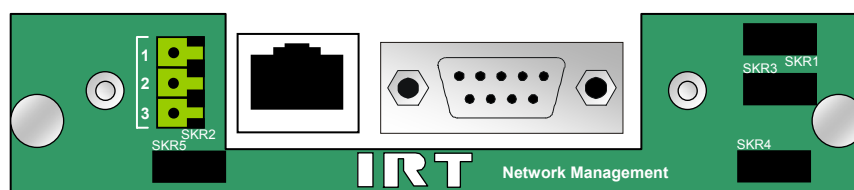

CDM-1000 Setup

The communication between the CDM-1000 and the NMSs use Ethernet at either 10 or 100Mb/s.

The SNMP protocol used is Version 1. Read and Write functions use the same Community string.

To obtain a response from a CDM-1000 the Internet Protocol (IP) Destination address must be the preconfigured Local IP Address, the IP Source Address must be one of the pre-configured NMS addresses, the UDP Port number must match the preconfigured Agent Port, and the Community string must match the pre-configured Community string.

The Community string is also used to address individual modules. The frame slots are numbered from 1 to 2, left to right as viewed from the front of the frame. To address a module the first character of the Community string must be the module Slot number in ASCII. The second character must be "@". The remaining characters must match the pre-configured Community string. For example suppose the Community was set as "public" then the module in Slot 1 would respond to "1@public" The CDM-1000 can also be addressed as being in slot '0' (i.e. "0@public" or "public").

To configure the CDM-1000 connect an ASCII serial RS-232 terminal (such as Tera Term PRO) to the Configuration port. The data rate should be 9600 baud and the byte should 8 bits data, no parity 1 stop. Upon sending 'Enter' you would typically see the following:

```
1.Local MAC address 12:34:56:78:9A:DF
2.Local IP address 192.168.0.100
3.NMS 1 IP Address 192.168.0.11    00:A0:CC:54:12:84
4.NMS 2 IP Address 255.255.255.255
5.NMS 3 IP Address 192.168.0.10    00:A0:CC:54:12:8E
6.NMS 4 IP Address 192.168.0.24    00:A0:CC:54:12:86
7.NMS 5 IP Address 192.168.0.9     00:09:5B:04:16:48
8.Gateway IP Address 192.168.0.1   00:09:5B:12:33:15
9. Subnet Mask      0.0.0.0
A.Community        public
B.Agent Port       161
C.Trap Port        162
D.sysContact       John Doe
E.sysLocation      Hotham Pde
F.sysName          north side
```

To change a parameter, type in the line number that you wish to change. As soon as the line number has been typed you are able to enter the new parameter data. Pressing the 'Enter' key will give you a message asking if you wish to replace the existing data with the new data. Press 'Enter' again to accept the change. Anything else typed will default back to the existing parameter.

Local MAC address

This is a unique address of this particular CDM-1000 and should only be changed with great care.

Local IP address

This is the static IP address assigned to the Frame by you or your ISP.

NMS 1 IP Address

This is the IP address of one of the NMSs to which the CDM-1000 will respond. Up to 5 addresses can be used. If any one of the addresses is not required then the address 255.255.255.255 should be entered.

Once communication has been established with a particular address then the MAC address used to communicate with that IP address will be displayed after the IP address. If the IP address is not within the local subnet as defined by the Gateway address and the Subnet Mask then instead of the MAC address the label "via Gateway" will appear.

Gateway IP Address

When using subnets a Gateway is the IP address of the computer appointed to pass on all messages that are addressed to computers that are not part of your subnet. **The Gateway IP address must be in your subnet.**

Subnet Mask

A subnet mask is used to determine if an IP address is within your subnet or not. If the IP address is within your subnet then you send messages directly to that IP address. If it is not then you send messages to the Gateway for it to pass on.

Say the mask was 255.255.0.0 – and the destination IP address was 192.168.0.54 and the Gateway address was 192.168.0.1. Using binary logic you AND the IP address and the mask which results in 192.168.0.0 . Now AND the mask and the Gateway address and you get 192.168.0.0 . These two addresses match so the destination is in your local subnet.

If you do not want to use Gateways set the Mask to 0.0.0.0

Community

This is the Community string, which must be exactly matched for a response to be obtained. It is case sensitive and you may use non-printable characters. The maximum length is 63.

Agent Port

This is the Agents UDP Port number. SNMP Protocol suggests that this should be 161.

Trap Port

When a Trap (an unsolicited message from a module to a NMS) is sent the Trap Port number is used as the destination port. SNMP Protocol suggests that this should be 162. Note that when a module generates a trap, it is sent to all of the configured NMS addresses using this Port number.

sysContact

This string is sent when a 'Get sysContact' is sent to the CDM-1000. Maximum length is 63 and only printable characters should be used.

sysLocation

This string is sent when a 'Get sysLocation' is sent to the CDM-1000. Maximum length is 63 and only printable characters should be used.

sysName

This string is sent when a 'Get sysName' is sent to the CDM-1000. Maximum length is 63 and only printable characters should be used.

IRT-MIB.my is an SNMP MIB, which contains the Object Identifier (OID) definitions of all IRT controllable modules. It also contains a small number of OIDs used by modules that do not have their own MIB.

IRT4000FRU-MIB.my is an SNMP MIB for all IRT SNMP frames fitted with a CDM SNMP agent controller. A 'Walk' command to a CDM-1000 will show (in part) a list by slot number of the type of module installed.

If enabled, Trap alarms can be individually enabled or disabled for each slot position.

SNMP Plug-in Management Controller Type SMU-4000

SMU-4000 General Description

The SMU-4000 is a Simple Network Management Protocol (SNMP) plug-in interface option for IRT 4000 series modules when used in IRT's SNMP capable frames.

The SMU-4000 is programmed with a Management Information Base (MIB) suitable for the type of module that it is to be plugged into.

IRT 4000 series cards that are SNMP upgradeable need the SMU-4000 plug-in module programmed with their own relevant MIB to be recognisable by the SNMP system.

The SMU-4000 acts as an interface between the module that it is plugged into and the CDM-xxxx SNMP Agent within the SNMP capable frame. Module conditions such as alarm states or signal conditions are communicated to the SNMP Network Management System (NMS) via the CDM-xxxx SNMP Agent. Likewise control commands are communicated from the NMS, to the SNMP Agent, to the relevant module via the SMU-4000 plug-in module.

Features:

- **Plug-in SNMP option for IRT 4000 series cards**
- **Programmable Management Information Base (MIB) to suit intended module**

SMU-4000 Installation

The SMU-4000 plug-in SNMP management controller module can only be fitted to IRT's 4000 series modules that are capable of being SNMP upgradeable. To determine whether a module is SNMP upgradeable, a square section on the main PCB is silk screened and fitted with three multipin sockets – as shown below:

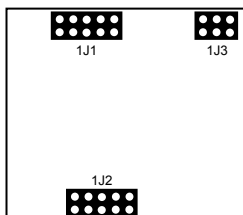

This is where the SMU-4000 plug-in SNMP management controller module is fitted. The three sets of multipins on the underside of the SMU-4000 line up with the three sets of multipin sockets on the main PCB module. Align all pins and then gently press the SMU-4000 all the way down into place.

If the SMU-4000 is not already programmed with the correct firmware to match the module that it is being plugged into, it then needs to be programmed via the pins on the topside of the SMU-4000.

Note that installation will generally be done by IRT Electronics at the time of ordering.

Note also that an SMU-4000 will only be functionally operational when the main module that it is plugged into is fitted into an IRT SNMP capable frame fitted with a CDM-xxxx SNMP agent and being interrogated by a suitable Network Management System.

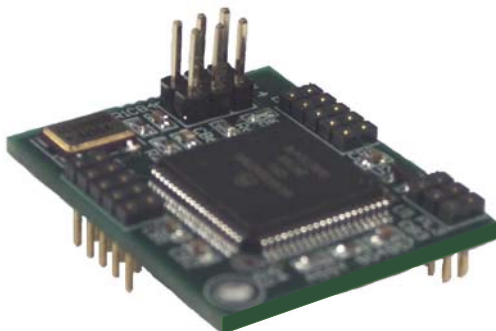

Figure 1: SMU-4000 module

SNMP

What Is It?

SNMP stands for Simple Network Management Protocol. It is an application layer protocol for managing IP (Internet Protocol) based systems. SNMP enables system administrators to manage system performance, and to find and solve system problems. SNMP runs over UDP (User Datagram Protocol), which in turn runs over IP.

Three types of SNMP exist: SNMP version 1 (SNMPv1), SNMP version 2 (SNMPv2) and SNMP version 3 (SNMPv3). It is not the intention here to discuss the differences between various versions, only to bring attention to the fact that IRT Electronics modules, fitted with SNMP capability, use SNMPv1.

An SNMP managed network consists of three key components: Network Management Systems (*NMS*), *agents*, and *managed devices*.

An *NMS* is the console through which the network administrator performs network management functions, such as monitoring status (e.g. alarm states) and remote controlling, of a set of managed devices. One or more *NMS*s must exist on any managed network. Generally the *NMS* is a computer running third party SNMP control software. There are a number of third party SNMP software applications currently available on the market.

An *NMS* polls, or communicates with, an *agent*. An *agent* is a network management software module that resides in a *managed device*. An *agent* has local knowledge of management information and translates that information into a form compatible with SNMP. The *agent*, therefore, acts as an interface between the *NMS* and the managed devices. The *NMS* sends a request message, and control commands for the managed devices, to the *agent*, which in turn sends a response message, containing information about the *managed devices*, back to the *NMS*.

A *managed device* contains an SNMP *agent* and resides on a managed network. *Managed devices* collect and store management information and make this information available to *NMS*s using SNMP.

Managed device agent variables are organised in a tree structure known as a Management Information Base (*MIB*). Within the *MIB* are parameters pertaining to the *managed device*. An Object Identifier (OID) number within the *MIB* defines the managed device type. This is a unique number specific to the model of *managed device*. Other information relating to the device is also stored, information such as alarm states, controllable settings, etc. The *MIB* tree is organised in such a way that there will be no two *MIB* files with conflicting placements.

Normally an *NMS* polls an *agent* for information relating to the *MIB* in a managed device to be sent back to the *NMS*. When certain conditions are met within the *MIB*, such as major alarm conditions, for example, the *agent* automatically sends what is known as a *trap* to the *NMS* without any prompting from the *NMS*. This allows automatic notification of a predetermined event.

SNMP Block Diagram

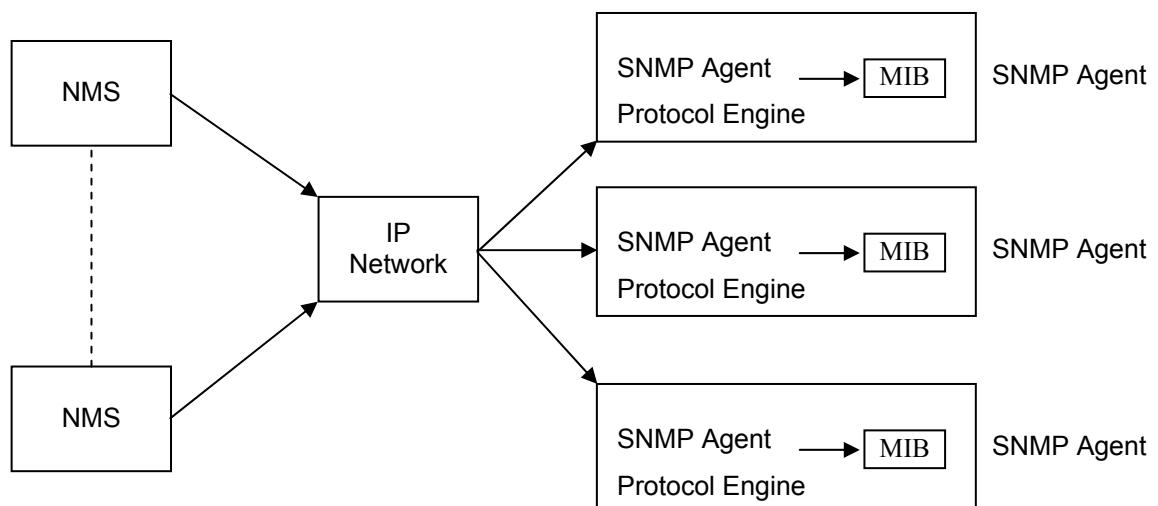

SNMP with IRT Products:

IRT Electronics currently employs SNMPv1 with its SNMP capable frames. The frame acts as an *agent* when fitted with a CDM-xxxx module. This module has its own designated slot next to the power supply so as to not affect the number of modules that the frame will take. Communication between the *NMS*, the frame and its loaded modules are via this CDM-xxxx module. Note that the *NMS* software is third party and not supplied by IRT Electronics.

Ethernet connection for SNMP operation is via an RJ45 connector on the rear of the frame, below the mains inlet. Ethernet rate runs at either 10 baseT or 100 baseT.

Frame parameters, such as Name, Address and Location, are set via an RS232 interface, a D9 connector on the rear of the frame below the mains inlet. A software terminal emulator, such as Tera Term or HyperTerminal, is used for setting and reading the parameters of the frame.

IRT modules that are SNMP compatible need a plug-in SMU-4000 module with a program relevant to the module that it is plugged into. Depending on the module, besides the module identification, parameters such as alarm states, inputs and controls etc. are communicated to the CDM-xxxx *agent* via a data bus on the rear of the frame. Thus the CDM-xxxx collects information on what is loaded within the frame, what positions they occupy, and their current status for communication to the *NMS* when the *NMS* sends a request for information.

In the event of a major alarm from any of the SNMP compatible modules, or power supplies, a *trap* is automatically sent by the CDM-xxxx *agent* to the *NMS* without any prompting by the *NMS*. This alerts the operator to any fault conditions that may exist that need immediate attention.

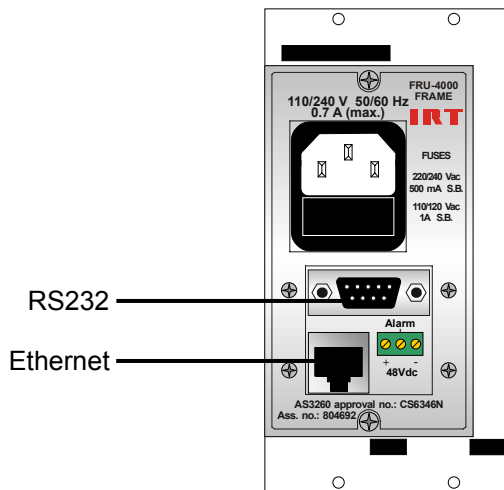

IRT SNMP Connections

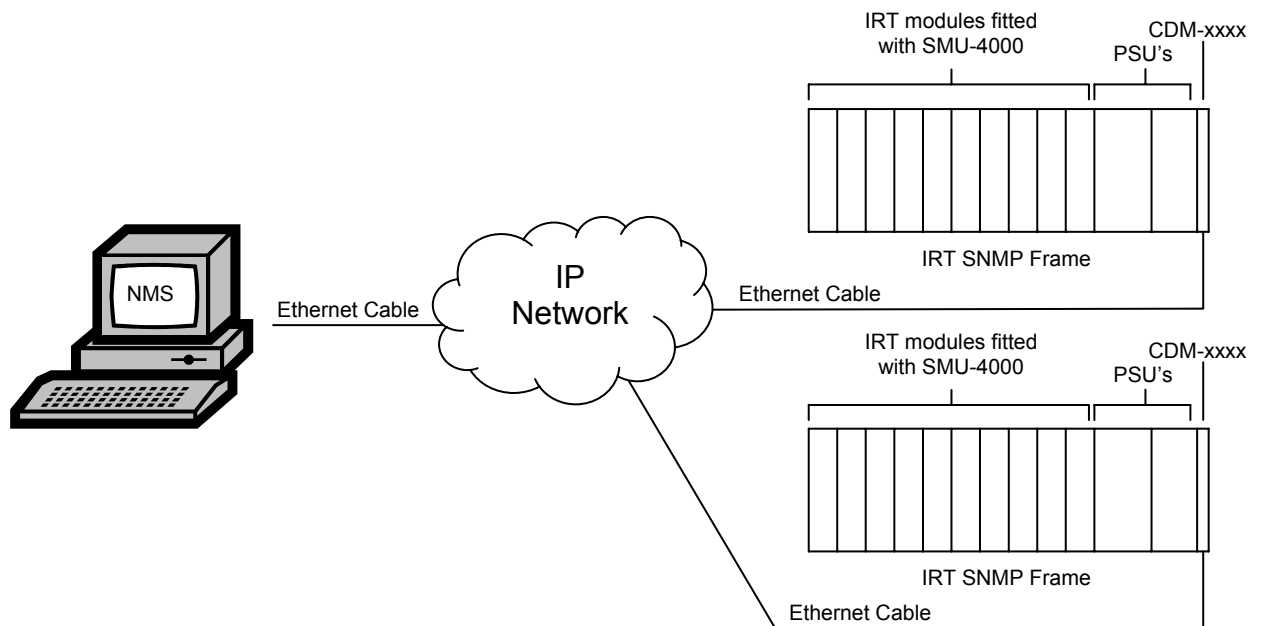

IRT SNMP Setup

Warranty & Service

Equipment is covered by a limited warranty period of three years from date of first delivery unless contrary conditions apply under a particular contract of supply. For situations when “No **Fault Found**” for repairs, a minimum charge of 1 hour’s labour, at IRT’s current labour charge rate, will apply, whether the equipment is within the warranty period or not.

Equipment warranty is limited to faults attributable to defects in original design or manufacture. Warranty on components shall be extended by IRT only to the extent obtainable from the component supplier.

Equipment return:

Before arranging service, ensure that the fault is in the unit to be serviced and not in associated equipment. If possible, confirm this by substitution.

Before returning equipment contact should be made with IRT or your local agent to determine whether the equipment can be serviced in the field or should be returned for repair.

The equipment should be properly packed for return observing antistatic procedures.

The following information should accompany the unit to be returned:

1. A fault report should be included indicating the nature of the fault
2. The operating conditions under which the fault initially occurred.
3. Any additional information, which may be of assistance in fault location and remedy.
4. A contact name and telephone and fax numbers.
5. Details of payment method for items not covered by warranty.
6. Full return address.
7. For situations when “No **Fault Found**” for repairs, a minimum charge of 1 hour’s labour will apply, whether the equipment is within the warranty period or not. Contact IRT for current hourly rate.

Please note that all freight charges are the responsibility of the customer.

The equipment should be returned **to the agent who originally supplied the equipment** or, where this is not possible, to IRT direct as follows.

Equipment Service
IRT Electronics Pty Ltd
26 Hotham Parade
ARTARMON
N.S.W. 2064
AUSTRALIA

Phone: 61 2 9439 3744

Fax: 61 2 9439 7439

Email: service@irtelectronics.com