



IRT Electronics Pty Ltd A.B.N. 35 000 832 575
26 Hotham Parade, ARTARMON N.S.W. 2064 AUSTRALIA
National: Phone: (02) 9439 3744 Fax: (02) 9439 7439
International: +61 2 9439 3744 +61 2 9439 7439
Email: sales@irtelectronics.com
Web: www.irtelectronics.com

IRT Eurocard
Type CDC-3062
Priority Controller

Designed and manufactured in Australia
IRT can be found on the Internet at:
<http://www.irtelectronics.com>

IRT Eurocard
Types CDC-3062
Priority Controller
Instruction Book

Table of Contents

Section	Page
Functional Diagram	3
General Description	3
Operational Description	4
Technical Specifications	6
Technical Description	7
Internal Adjustments	8
Configuration	9
Link settings	9
Audio only operation	10
Installation	11
Operational Safety	11
Pre-installation	11
Installation in frame or chassis	12
Connections	12
Front & rear panel connector diagrams	15
Maintenance & Storage	16
Warranty & Service	16
Equipment return	16
Drawing index	17

This instruction book applies to units later than S/N 9704001.

Functional Diagram

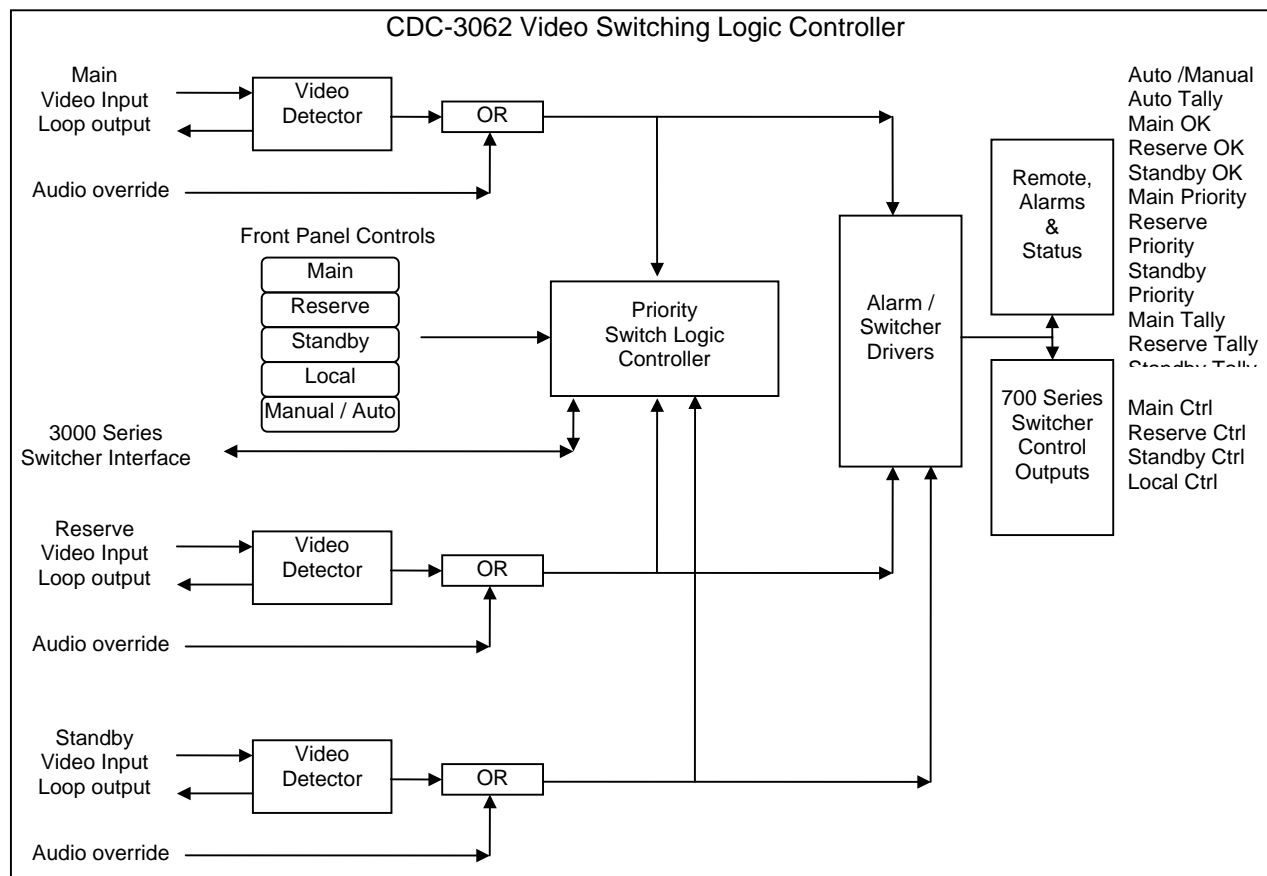

General Description

The CDC-3062 is a video presence detector that also provides logic and switching control circuitry for interfacing to IRT 700, 3000 & 4000 series video and audio switchers. The main use for the controller is to provide control of transmission link paths and to provide alarm and status information to centralised monitoring facilities.

The following features are provided:

- Automatic operation.
- Selection of main / reserve / standby priority.
- Local / remote control of all functions.
- Remote and local status information.
- Audio fail override facility using IRT AG-738 / AAD-4130 audio detector.

The video signals of the *main*, *reserve* and *standby* paths are monitored, with an indication provided to show the loss of the input signal. Any of the *main*, *reserve* or *standby* paths can be selected as the priority path and, provided a signal is present, this selection will be the ON AIR source.

If the priority selected path should fail the unit will provide control signals to select another input. Where a failure occurs on *main*, *reserve* and *standby* inputs then the system will select the *local* input. Once any input signal is restored, the system will switch back from the *local* signal to an input signal, with the priority-selected input having precedence when more than one input signal is available.

The front panel indicators and controls provided are:

- Fail LED's on the main, reserve and standby paths.
- Indication of the priority source selected.
- Indication of the ON AIR source.
- Auto/manual enable indication.
- Push buttons for priority selection of sources in auto mode and direct selection of manual mode.

Operational Description

The CDC-3062 Eurocard module has three video failure detectors; designated *main*, *reserve* and *standby*.

Full interfacing to IRT 3000 series Eurocard switchers is provided, in addition it also has four logic level outputs for selecting one of four crosspoints on an IRT Eurocard series switcher. (Types VA-710, AA-720 and / or AA-751 (obsolete))
The four crosspoints may be designated *main*, *reserve*, *standby* and *local*.

The controller may be operated in one of two modes; *manual* or *auto*.

Manual mode:

In manual mode, the four front panel switches provide direct selection of the four controlled crosspoints.

Switching between *auto* and *manual* modes may be made using the front panel pushbutton switch or by an opto-isolated remote interface. The action of this switch / remote input is a toggle action and it is therefore essential that this switch be returned to the *auto* position once any servicing work requiring manual operation is completed.

A visual indication of manual mode is provided by the red LED immediately below the *manual* switch. A remote tally of this mode is also provided so that the mode is known when operated by remote control.

Auto mode:

In auto mode, the four front panel switches are used to set the "priority" of the four crosspoints.

If *main* has the priority then:

- If a valid signal is present on *main* then *main* is selected.
- If *main* fails and a valid signal is present on *reserve* then *reserve* is selected.
- If *main* and *reserve* both fail and a valid signal is present on *standby* then *standby* is selected.
- If *main*, *reserve* and *standby* all fail then *local* is selected.

If *reserve* has the priority then:

- If a valid signal is present on *reserve* then *reserve* is selected.
- If *reserve* fails and a valid signal is present on *main* then *main* is selected.
- If *main* and *reserve* both fail and a valid signal is present on *standby* then *standby* is selected.
- If *main*, *reserve* and *standby* all fail then *local* is selected.

If *standby* has the priority then:

- If a valid signal is present on *standby* then *standby* is selected.
- If *standby* fails and a valid signal is present on *main* then *main* is selected.
- If *standby* and *main* both fail and a valid signal is present on *reserve* then *reserve* is selected.
- If *main*, *reserve* and *standby* all fail then *local* is selected.

If a failed signal is restored then selection takes place according to the above priorities.

A video failure is deemed to have occurred when the synchronising signals of a composite video signal fall in level by more than 6 dB from standard.

Front panel controls & indicators:

Pushbuttons:

The front panel has four selector pushbuttons called *main*, *reserve*, *standby* and *local*.

In *manual*, these are used to select crosspoints 1, 2, 3 & 4 of the connected video switcher.

In *auto*

- main* sets *main* as the priority channel
- reserve* sets *reserve* as the priority channel.
- standby* sets *standby* as the priority channel.

Each switch has an LED indicator.

In *manual* mode, the LED's act as tallies indicating the selected path.

In *auto* mode the LED's act both as tallies and indicators of the currently selected priority by intermittently flashing.

Pressing either the *main*, *reserve* or *standby* switches for a period longer than 2 seconds causes the selected switch to act as the priority.

Auto / manual switch:

This switch selects auto mode under the direction of the priority controller and failure detectors or manual mode for direct control regardless of failure status.

Note that the action of this switch is to toggle between the two modes and hence pressing the switch will change from the current mode to the other.

In order to know which mode is current a warning LED and remote tally is provided to indicate *manual* mode when selected.

Failure indicators:

An LED indicator is provided for the *main*, *reserve* and *standby* channels, which lights in the event of a failure being detected on that channel.

Technical Specifications

IRT Eurocard module

Type CDC-3062

Inputs:

Video

Type 3 x loop through.
 Connector BNC.

Extended failure

Type 3 x opto isolated failure override.

Control

IRT 3000 series switcher interface.

Type 5 bit BCD coded parallel TTL level.
 Number 1 "input" & 1 "output".
 Connectors Plug in 10 pin dual IDC.

Manual override

Type 1 x opto isolated manual / auto toggle.

Outputs

IRT 3000 series switcher interface As above.
 IRT 700 series switcher interface TTL level

Alarm tallies

Function Auto mode enabled
 Main present
 Reserve present
 Standby present
 Main has priority
 Reserve has priority
 Standby has priority
 * Main tally
 * Reserve tally
 * Standby tally
 * Local tally
 * Not available when using 700 series switchers.
 Type TTL level
 or
 Open collector transistor 100 mA @ 30 Volts.

Performance

Detection threshold -6 dB referenced to 1 Vp-p composite video signal. (Factory setting).
 Internal pre-set adjustment, effective in the range 0.4 to 0.7 Vp-p composite video.

Response time: Alarm active 12 ms after sync loss.
 Alarm reset 1 to 1.25 seconds after sync return.

Power Requirements:

Power consumption 28 Vac CT (14-0-14) or \pm 16 Vdc.
 <3 VA.

Other:

Temperature range 0 - 50° C ambient.
 Mechanical Suitable for mounting in IRT 19" rack chassis types FR-700 & FR-722 with input output and power connections on the rear panel.
 Finish: Front panel Grey background, silk screened black lettering & red IRT logo.
 Rear assembly Detachable silk-screened PCB with direct mount connectors to Eurocard and external signals.
 Dimensions 6 HP x 3 U x 220 mm IRT Eurocard.
 Supplied accessories Rear connector assembly.
 Optional accessories Instruction manual.
 TME-6 module extender card.

Technical Description

See drawing 804084 sheets 1 - 2.

Video inputs.

Each video input connects to a high impedance emitter follower buffer that allows a loop through connection to be made if required. If the loop through is not connected, a 75 Ohm termination BNC connector should be fitted to the loop through socket to ensure correct levels are present at the detector.

The detector circuit uses an Elantec EL4583C integrated circuit. Pin 2 is the "Set Detect Level" and determines the value of the minimum signal that will trigger the "No Signal Detect Output" on pin 10.

The relationship is $V_{pMIN} = 0.75 * RV 1 / 680 K$, where V_{pMIN} is the minimum detected sync pulse amplitude applied to pin 4. The detection operates on both horizontal and vertical sync.

The delay from loss of input signal to "No Signal Detect Output" is typically 600 μ s. This is too fast for this application as the loss of an individual horizontal sync pulse is of no consequence.

Furthermore, if the sync pulse level falls to near the threshold any noise on the signal will cause repetitive triggering. As the switchers being controlled normally switch only during the vertical interval, a delay of up to one field will not effect switching performance.

To overcome these problems the "No Signal Detect Output" is passed through a filter circuit that both increases the time constant and introduces hysteresis to provide differing "ON" and "OFF" timing.

Response time is set by the time constant for charging / discharging C 6, 14, 22. The diode isolates the charging and discharging paths.

The resistor values shown are found to be good for most applications, but may be changed if required.

Alarm active - factory set	12 ms after sync loss.	R 7, 16, 25.
Alarm reset - factory set	1 to 1.25 seconds after sync return.	R 8, 17, 26.

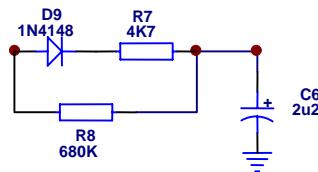

The output of the hysteresis circuit is connected to an LM311 comparator with open collector output. See *Audio only operation* for a detailed description of this part of the circuit.

Audio override inputs.

The name of these inputs is not intended to imply that they be used for audio signals, but rather that they are normally used for alarm outputs from audio fail detectors.

They may in fact be used with any type of external alarm signal, for example those available from digital decoders or timebase correctors.

Due to the complexity of decision making in determining what constitutes an audio failure, this is left to a separate module. See IRT's AG-738 stereo failure detector manual.

The audio override inputs are via opto isolators and may be configured for various modes of input signal. See *Configuration* for more details.

Logic processing.

The outputs of the three path alarm inputs, switch data and other inputs and outputs are processed and controlled by U 12. This programmed logic controller contains firmware programming which provides the necessary logic functions. It is only available from IRT and cannot be serviced in the field except by replacement with an IRT supplied chip.

A full explanation of the programming is beyond the scope of this manual.

Tally & status outputs.

See also information under *Installation - Connections*.

The tally and status outputs from the PLA logic chip are buffered by 75452 relay / lamp drivers with open collector outputs. These provide ample current and voltage rating for normal applications. Links are provided to allow a choice between a logical voltage output and a current sinking output.

The *Reserve OK* and *Standby Tally* are not provided with these links due to space limitations. These outputs require an external pullup resistor if they are to provide voltage outputs.

Remote automatic/ manual operation input.

This input is opto-isolated using the same technique as the Audio Override inputs. The action of this input is to toggle between manual and automatic modes of operation. The opto-isolator output is directly connected to the front panel switch that provides the same function and so either will cause a change of mode. See *Installation - Connections* for more information.

Switcher interface:

The connections from the PLA chip to an IRT 3000 series switcher are via connectors PL 4 & PL 5. For a full description of this interface and switcher protocol, see the *3000 Series Switchers* manual.

Relay Function:

(Applies to serial numbers later than 9912000 only. See circuit diagram 804084 Sheet 1 rev. 2+ and 804084 sheet 3)
A relay is mounted on the rear connector unit via PL3 for connecting to any of the alarm outputs via PL1 to provide a relay closure alarm output. Connection is made by the user connecting pin PL3-8A to the chosen relevant pin on PL1.

Power supply:

The module may be powered by AC or DC, single or dual supplies. Resistors F 1 to F 4 provide fusing protection to the power supply buss in the event of catastrophic failure of the module. If the module is subjected to continuous high voltage supply input, these resistors might go high in value with a consequent loss in voltage delivered to the regulator circuits and consequent loss of regulation.

Diode bridges D 1 to 4 and 5 to 8 function as full wave rectifiers for AC supplies and as reverse voltage connection protection and isolation for DC supplies.

A standard 3 pin voltage regulator is used to provide the +12 Volt supply rail.

The +5 Volts required by the logic circuits are supplied from a DC/DC converter. This is connected across the positive and negative unregulated supplies so that a balance is maintained in the current drawn from these two sources. This would normally result in a higher than normal input voltage being applied to the converter. So the combination of resistors R 55, R 56 and Zener diode ZD 1 are included to ensure that the converter is always operated within its safe input margin.

Capacitors C 25, 36, 37 and 38 are located at key points in the circuit layout to provide local high frequency bypass to the +5 Vdc supply.

Internal Adjustments

The following adjustable resistors are factory set and should not be adjusted unless a component has been replaced. They are not 'operational' controls. Before adjusting any of these controls, allow time for the module to reach temperature stability.

RV 1	Main video sync failure sensitivity.
RV 2	Reserve video sync failure sensitivity.
RV 3	Standby video sync failure sensitivity.

Correct setting for each of the above is as follows:

Apply a 1V video signal via a 75 Ohm attenuator box to the video input and set the corresponding control so that the corresponding front panel FAIL LED is off with 6 dB attenuation and on with 7 dB attenuation.

Configuration

Link settings:

Links are provided on the Audio Override inputs and on the most commonly used external tally outputs. These links are used as follows.

Audio Override Links: LK 1, LK 2 & LK 3.

The circuit for one input only is shown. All inputs have the same arrangement and may be individually configured. Only one will therefore be described. See dwg 804084/1 for full circuit details.

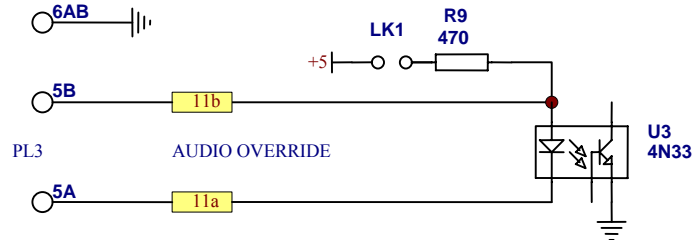

To drive from a relay contact closure to ground configure as follows:

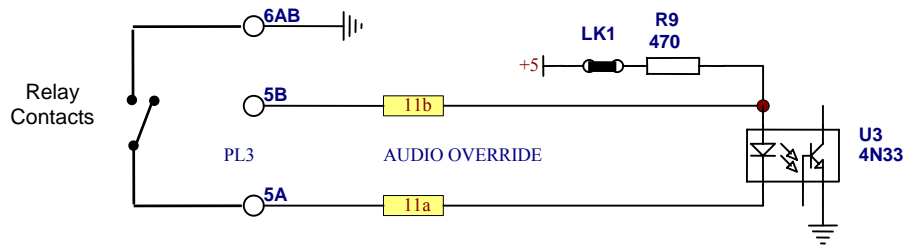

Audio only operation:

The CDC-3062 may be used without video for audio only applications or for use with general alarm signals using the audio override inputs. This allows the complex logic of the CDC-3062 to be applied to many situations where analogue video is not present, but fail alarms are provided.

These include digital video, audio, data, FSK and ACS path switching.

The output of each video sync detector is fed to a comparator's inverting input. The non-inverting input is connected to a reference voltage formed by resistors R 28 & R 29. By removing R 29 the comparison is now made to +5 Vdc. This will result in the output of the comparator always being high.

Note that this modification affects all three video inputs. Its main advantage is that it may be done simply by snipping the lead at one end of the resistor and can easily be restored later if the required use changes.

If only one or two video inputs are to be disabled, the LM311 for those inputs should be removed.

The comparator used is an LM311, which has an open collector output.

Functional block diagram

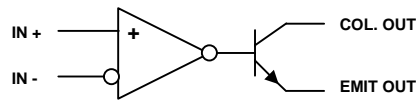

The collector is normally pulled high to +5 Vdc by a 560 Ohm resistor (R 51, 52 or 53) and the control panel LED failure indicator for that channel.

The open collector output allows a second connection to be made from the audio override input. This can also pull the output line low and so the arrangement functions as an OR gate for the two alarm sources.

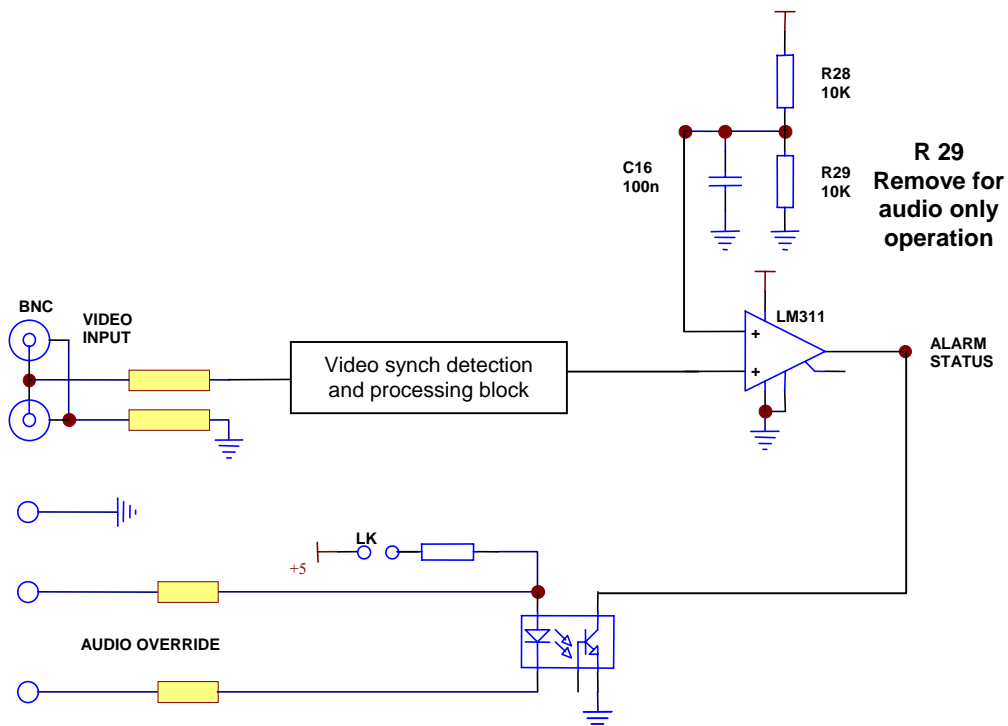

Installation

Operational Safety:

WARNING

Operation of electronic equipment involves the use of voltages and currents that may be dangerous to human life. Note that under certain conditions dangerous potentials may exist in some circuits when power controls are in the **OFF** position. Maintenance personnel should observe all safety regulations.

Do not make any adjustments inside equipment with power **ON** unless proper precautions are observed. All internal adjustments should only be made by suitably qualified personnel. All operational adjustments are available externally without the need for removing covers or use of extender cards.

Pre-installation:

Handling:

This equipment may contain or be connected to static sensitive devices and proper static free handling precautions should be observed.

Where individual circuit cards are stored, they should be placed in antistatic bags. Proper antistatic procedures should be followed when inserting or removing cards from these bags.

Power:

AC mains supply: Ensure that operating voltage of unit and local supply voltage match and that correct rating fuse is installed for local supply.

DC supply: Ensure that the correct polarity is observed and that DC supply voltage is maintained within the operating range specified.

Earthing:

The earth path is dependent on the type of frame selected. In every case particular care should be taken to ensure that the frame is connected to earth for safety reasons. See frame manual for details.

Signal earth: For safety reasons a connection is made between signal earth and chassis earth. No attempt should be made to break this connection.

Installation in frame or chassis:

See details in separate manual for selected frame type.

Connections:

Video:

The three video inputs provided are of a loop through type and must be terminated in 75 Ohms. Use either a termination plug on the second BNC connector provided for each input or connect the second BNC connector to another piece of equipment where the 75 Ohm termination is made.

In normal use, it is expected that the CDC-3062 will be connected at the end of any chain of equipment whose inputs are looped to provide the maximum sensing capability for a fault in these connections. In a PIE (Program Input Equipment) configuration, the input to the program switcher controlled by the CDC-3062 should loop through the switcher input and then be connected to the corresponding CDC-3062 input, where it is terminated using a 75 Ohm BNC termination plug.

Audio override: (External alarm inputs)

The *main*, *reserve* and *standby* opto-isolated audio override inputs provide for optional connection of an IRT AG-738 / AAD-4130 audio failure detector.

Although termed audio override inputs these inputs may be used for the insertion of any external alarm by means of a contact closure or a DC voltage. See *Configuration*.

Note that an audio signal should not be applied to these inputs. The term audio override is derived from the input frequently being used in conjunction with an audio loss detector.

Care should be taken to ensure that the correct pins of connector PL 3 are connected according to the type of alarm input.

Two connections are provided: One is normally tied to the internal +5 Vdc supply via a series resistor.

For normally open contacts, the -ve serves as a grounding contact to activate the failure indication.

For normally closed contacts the -ve should be connected to ground and the +5 V connected to the normally closed contact to ground.

The internal supply connection may be disabled by a link (LK1, LK2, LK3) on the main module if required. However, if this is done care should be taken to ensure that the correct supply polarity is observed and that a series resistor is included to limit the current through the diode of the opto-isolator. This should not exceed 20 mA.

PL 3 Audio override inputs:

1A	Standby - +Vdc.
1B	Standby - -Vdc or contact closure to Gnd.
2A	Gnd.
2B	Gnd.
3A	Reserve - +Vdc.
3B	Reserve - -Vdc or contact closure to Gnd.
4A	Gnd.
4B	Gnd.
5A	Main - +Vdc.
5B	Main - -Vdc or contact closure to Gnd.
6A	Gnd.
6B	Gnd.
7A	Rear assembly RL1 relay N/O contact.
7B	Rear assembly RL1 relay COM contact.
8A	Rear assembly RL1 relay drive pin.
8B	No connection.

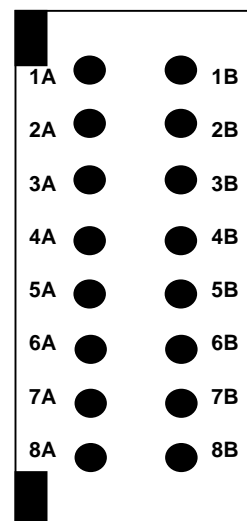

Tally & status outputs:

Tally and status outputs are provided to monitor the switcher status, program fail alarms and the currently assigned priority.

These outputs are driven by an open collector transistor driver and proper connection and loading must be observed. Please note the following limitations on output loading.

Absolute Maximum Ratings

Output Voltage 30V

The maximum voltage that should be applied to any output when it is in the "OFF" state.

Voltage values are with respect to network ground terminal.

Output Current 300 mA

Both halves of these dual circuits may conduct rated current simultaneously; however, power dissipation averaged over a short time interval must fall within the continuous dissipation rating.

Maximum Power Dissipation at 25 °C 957 mW

Derate 7.7 mW/ °C above 25 °C.

Note: "Absolute Maximum Ratings" are those values beyond which the safety of the device cannot be guaranteed. They are not meant to imply that the devices should be operated at these limits.

The following table of "Electrical Characteristics" provides conditions for actual device operation.

Electrical Characteristics

Symbol	Parameter	Conditions			Min	Typ	Max	Units
V _{OL}	Low-Level Output Voltage	V _{CC} = Min	V _{IH} = 2 V	I _{OL} = 100 mA		0.25	0.4	V
				I _{OL} = 300 mA		0.5	0.7	V
I _{OH}	High-Level Output Current	V _{CC} = Min	V _{OH} = 30 V	V _{IL} = 0.8 V			100	mA

PL 1 Tally & status outputs:

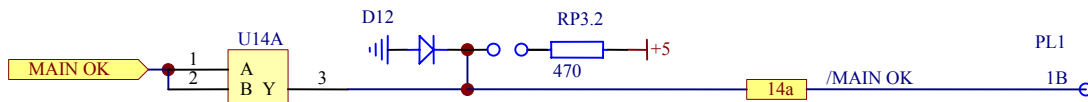

The following output nomenclature indicates the state represented by the output driver transistor in saturated condition i.e. the "ON" state.

Where links are installed as described in *Configuration* the "OFF" state will be approximately +5 Vdc and the "ON" state approximately 0.6 Vdc.

When used to drive relays directly, such as in the RL-740 the "OFF" state will be approximately +12 Vdc and the "ON" state approximately 0.6 Vdc.

1A	Auto
1B	Main O.K..
2A	Main has priority.
2B	Standby O.K..
3A	Main tally.
3B	Standby has priority.
4A	Local tally.
4B	Reserve tally.
5A	Reserve has priority.
5B	Standby tally.
6A	Reserve O.K..
6B	Gnd.

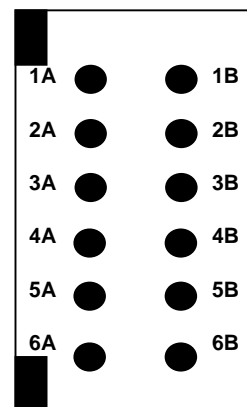

Remote control inputs:

The remote control inputs offer the same facilities as the pushbuttons provided on the front panel of the CDC-3062.

Selection is made by making a momentary clean contact to the Gnd connection.

Special care should be taken with the connection to the *Manual / Auto* function. This function is a toggle action and so any contact noise may be interpreted as more than one toggle command. If this input is to be used with relay or switch contacts that may not always provide a clean connection then noise suppression capacitors should be fitted to the contacts or a de-bouncing circuit should be included.

Intelligent use of this input can only be made when tally information is returned to the remote location. Without this information, the manual or automatic status cannot be assured.

The *Manual / Auto* input has been provided with an opto-isolator to improve immunity to damage by transient voltages. The remaining inputs have a degree of protection provided by series resistors between the control lines and the logic circuit. Care should be taken however to ensure good earthing of remote equipment to eliminate static discharge from passing down the control lines.

PL 2 Remote control inputs:

1A	Manual / Auto toggle.
1B	Standby select.
2A	Local select.
2B	Main select.
3A	Reserve select.
3B	Gnd.

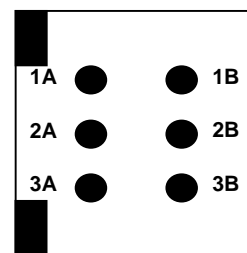

Program switcher connectors -(3000/4000 series Eurocard switchers):

Connection to the 3000/4000 series Eurocard switchers is made using 10 way ribbon cables observing the direction of PL 5 (out) connects to PL 4 (in) on either switchers, control panels or the CDC-3062.

The cables are wired on a pin for pin basis.

Before activating the switchers, control panels or the CDC-3062 priority controller a check should be made of all link settings on all switchers and panels to ensure that no conflicting settings are present.

In all cases, the number of switchers connected to one CDC-3062 should not exceed 10.

PL 4 IN & PL 5 OUT switcher control bus input & output:

	PL 4	PL 5
1A	+12 Vdc	No connection
1B	Ground	Same as PL 4.
2A	E - Data 4	"
2B	D - Data 3	"
3A	C - Data 2	"
3B	B - Data 1	"
4A	A - Data 0	"
4B	<i>Switch pulse in</i>	<i>Switch pulse out.</i>
5A	<i>Busy out</i>	<i>Busy in.</i>
5B	<i>Unlatch in</i>	<i>Unlatch out.</i>

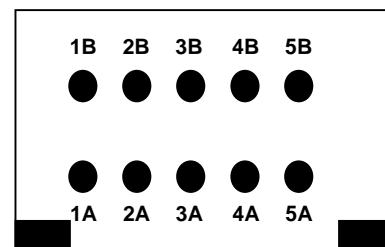

Front & rear panel connector diagrams

The following front panel and rear assembly drawings are not to scale and are intended to show relative positions of connectors, indicators and controls only.

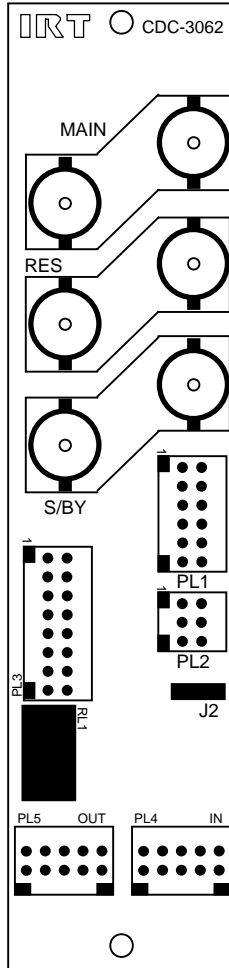
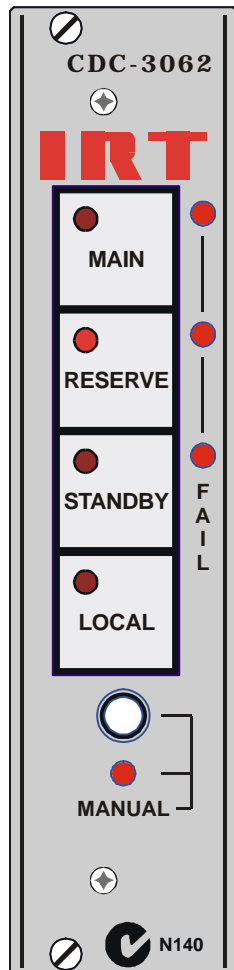

Old style rear assembly.
Not suitable for 4000
series frames
Serial Nos. < 0803001.

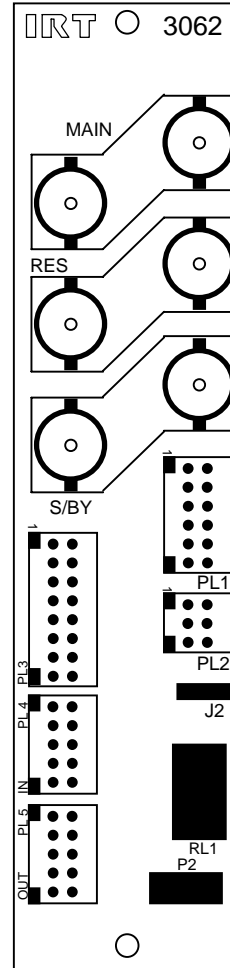

New style rear assembly.
Suitable for 4000 series
frames.
Serial Nos. ≥ 0803001

Maintenance & Storage

Maintenance:

No regular maintenance is required.

Care however should be taken to ensure that all connectors are kept clean and free from contamination of any kind. This is especially important in fibre optic equipment where cleanliness of optical connections is critical to performance.

Storage:

If the equipment is not to be used for an extended period, it is recommended the whole unit be placed in a sealed plastic bag to prevent dust contamination. In areas of high humidity a suitably sized bag of silica gel should be included to deter corrosion.

Where individual circuit cards are stored, they should be placed in antistatic bags. Proper antistatic procedures should be followed when inserting or removing cards from these bags.

Warranty & Service

Equipment is covered by a limited warranty period of three years from date of first delivery unless contrary conditions apply under a particular contract of supply. For situations when “**No Fault Found**” for repairs, a minimum charge of 1 hour’s labour, at IRT’s current labour charge rate, will apply, whether the equipment is within the warranty period or not.

Equipment warranty is limited to faults attributable to defects in original design or manufacture. Warranty on components shall be extended by IRT only to the extent obtainable from the component supplier.

Equipment return:

Before arranging service, ensure that the fault is in the unit to be serviced and not in associated equipment. If possible, confirm this by substitution.

Before returning equipment contact should be made with IRT or your local agent to determine whether the equipment can be serviced in the field or should be returned for repair.

The equipment should be properly packed for return observing antistatic procedures.

The following information should accompany the unit to be returned:

1. A fault report should be included indicating the nature of the fault
2. The operating conditions under which the fault initially occurred.
3. Any additional information, which may be of assistance in fault location and remedy.
4. A contact name and telephone and fax numbers.
5. Details of payment method for items not covered by warranty.
6. Full return address.
7. For situations when “**No Fault Found**” for repairs, a minimum charge of 1 hour’s labour will apply, whether the equipment is within the warranty period or not. Contact IRT for current hourly rate.

Please note that all freight charges are the responsibility of the customer.

The equipment should be returned **to the agent who originally supplied the equipment** or, where this is not possible, to IRT direct as follows.

Equipment Service
IRT Electronics Pty Ltd
26 Hotham Parade
ARTARMON
N.S.W. 2064
AUSTRALIA

Phone: 61 2 9439 3744

Fax: 61 2 9439 7439

Email: service@irtelectronics.com

Drawing Index

Drawing #	Sheet #	Description
804084	1 (Rev 1)	CDC-3062 video fail and control logic schematic. (For Serial Nos. < 9912000)
804084	1 (Rev 2)	CDC-3062 video fail and control logic schematic. (For Serial Nos. \geq 9912000)
804084	1 (Rev5)	CDC-3062 video fail and control logic schematic. (For Serial Nos. \geq 0803001)
804084	2	CDC-3062 main logic and PSU schematic.
804084	2 (Rev 5)	CDC-3062 video fail and control logic schematic. (For Serial Nos. \geq 0803001)
804084	3	CDC-3062 rear assembly connections. (For Serial Nos. \geq 0803001)

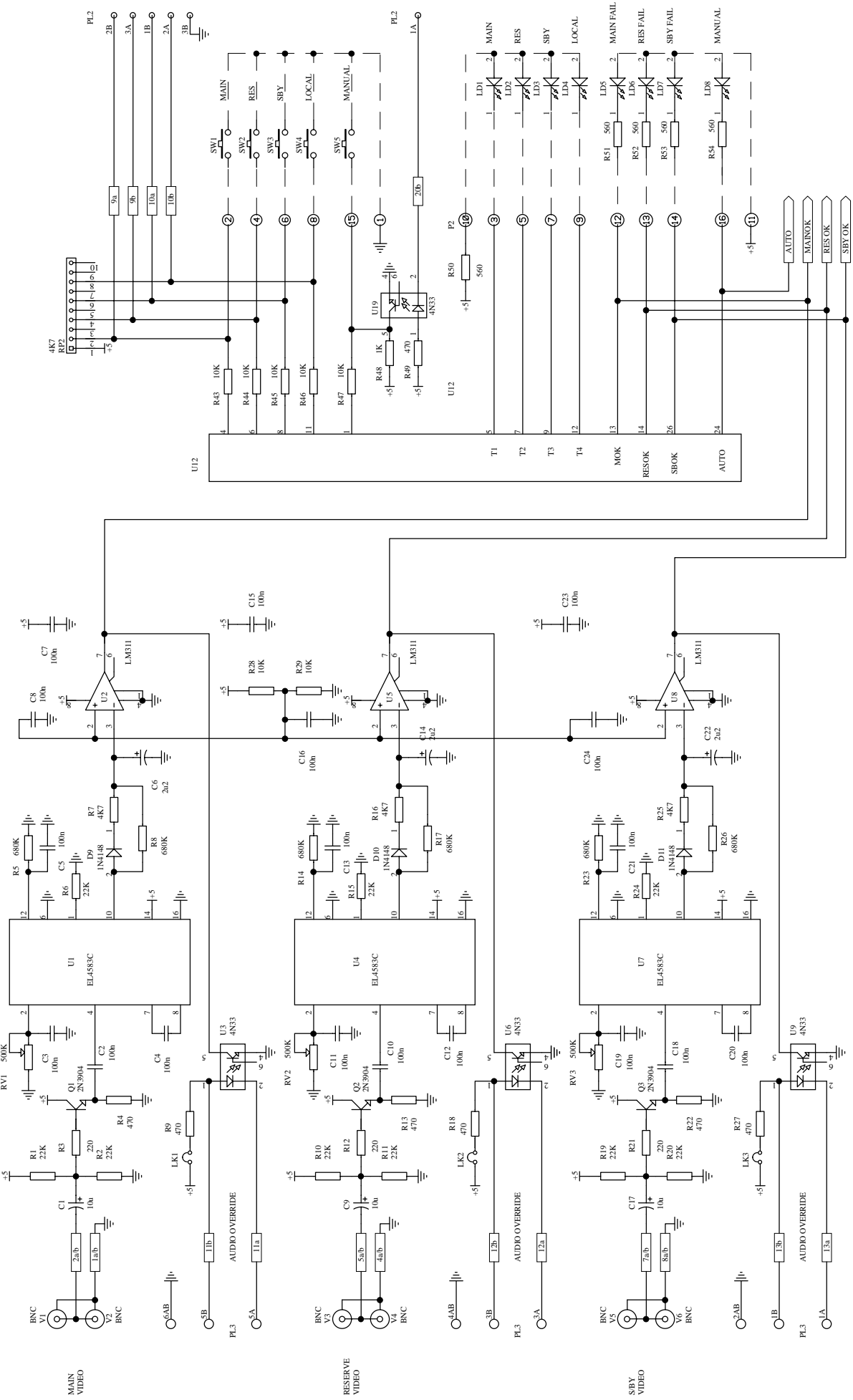

		TITLE	CDC-3062
		SIZE	VIDEO FAILURE LOGIC
COPYRIGHT DOES NOT COPY OR DISCLOSE TO ANY THIRD PARTY WITHOUT WRITTEN CONSENT		DRAWN	
		CHECKED	
1 15/04/97		SCALE	80/08/4
		ENG. APP.	
IRT Electronics Pty. Ltd. AKTARMON NSW AUSTRALIA 2064		DRAWING No.	80/08/4
		SHEET	1 OF 2

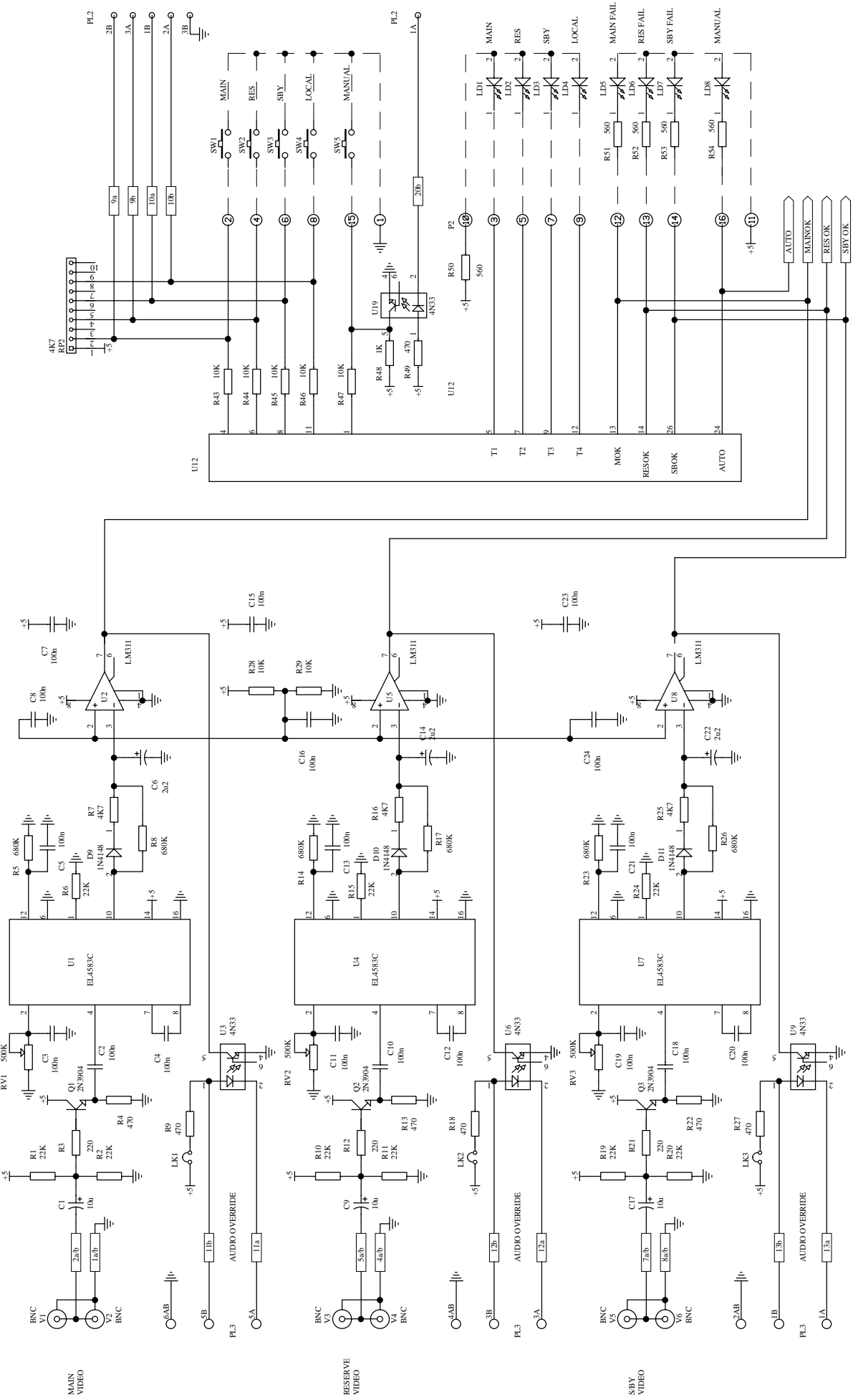

		TITLE	CDC-362
		SIZE	VIDEO FAILURE LOGIC
1 15/04/97 2 10/10/00	DRAWN	CHECKED	DRAWING No. 804084
	ENG. APP.		SHEET 1 OF 2
CONTRACT No.		IRT Electronics Pty. Ltd. AKTARMON NSW AUSTRALIA 2164	

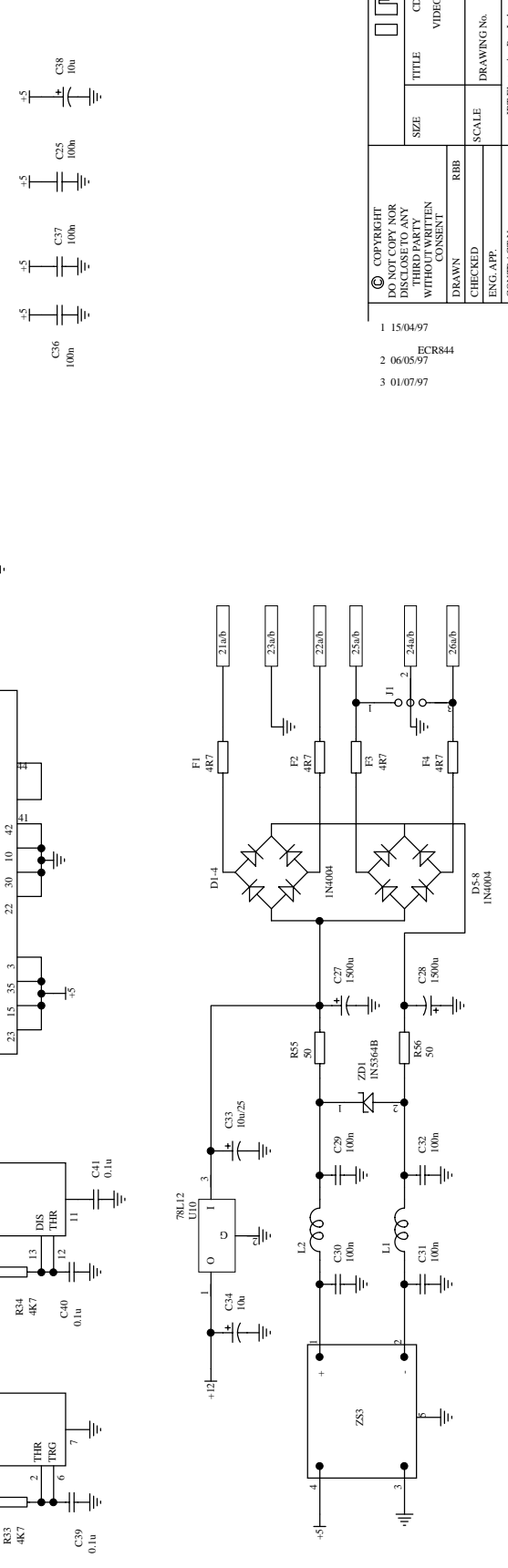
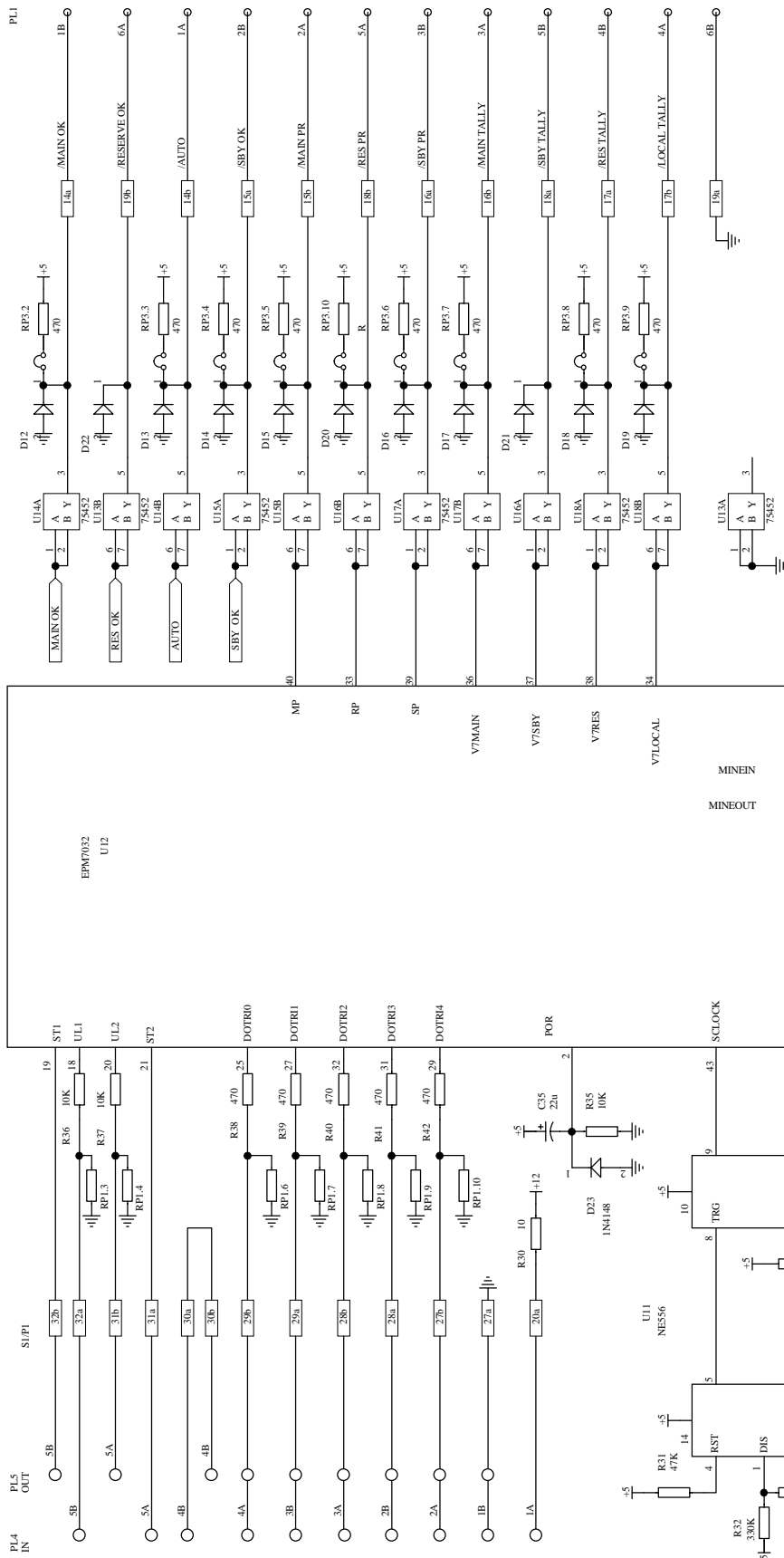

SIZE	CDC-3062
TITLE	VIDEO FAILURE LOGIC
SCALE	80/084
DRAWN	RBB
CHECKED	
ENG. APP.	
CONTRACT No.	
IRT Electronics Pty. Ltd. AKTARMON NSW AUSTRALIA 2064	

- 1 15/04/97
- 2 06/05/97 ECR844
- 3 01/07/97

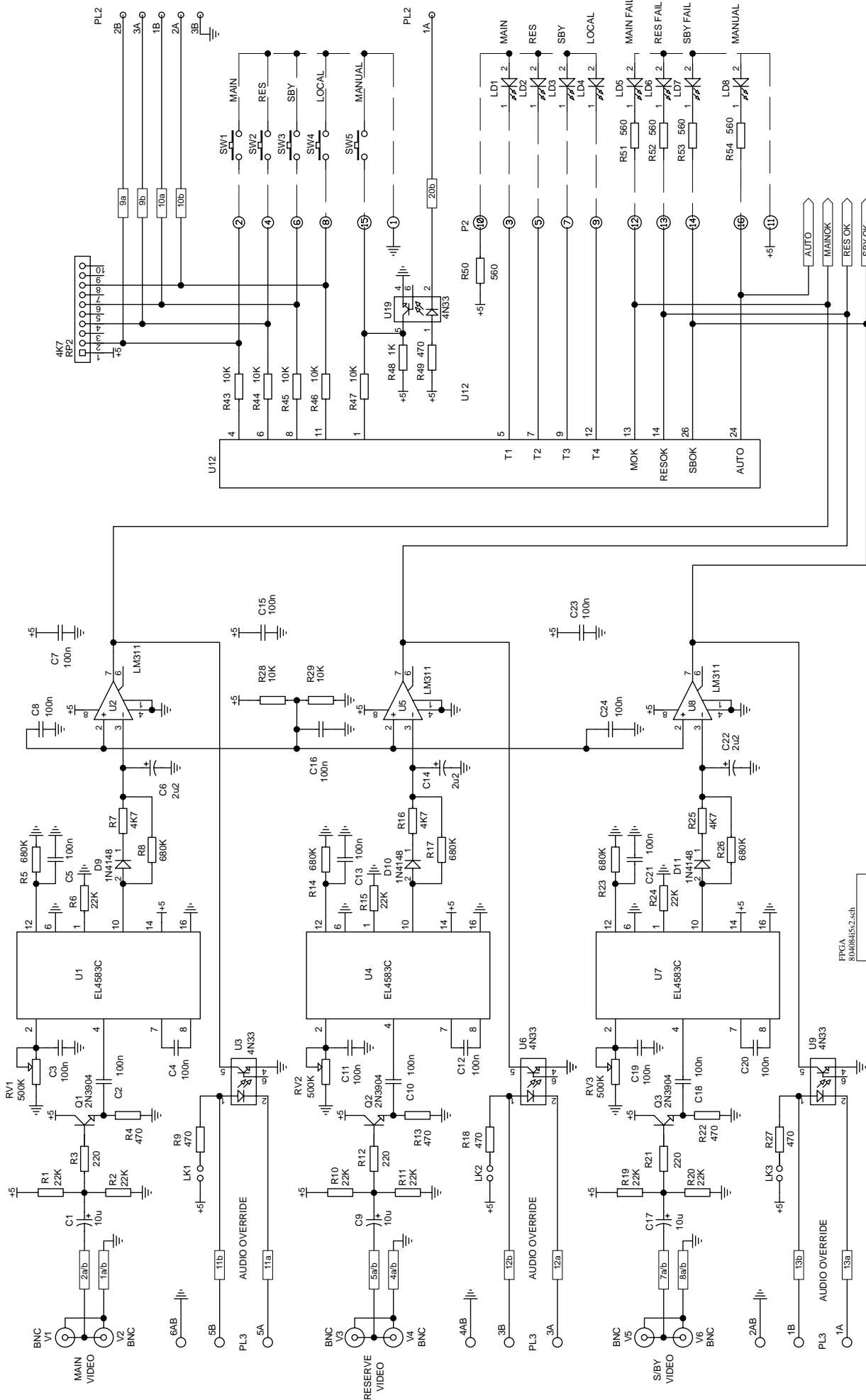

		Title	CDC-3062
		SIZE	A3
DO NOT COPY NOR DISSEMINATE WITHOUT WRITTEN CONSENT		DRAWN	ENG. APP.
		CHECKED	Revision: 5
1 15-04-97 2 6-05-97 3 1-07-97 ECR844 4 26-09-00 ECR1133 5 10-04-08 ECR1857		SCALE	N.T.S.
		Drawing No.	804084
		Sheet	1 of 3
		Date:	2-May-2008
		ARTARMON NSW AUSTRALIA 2064	

FPGA
 804084s5.2.sch
 R/A
 804084s5.3.sch

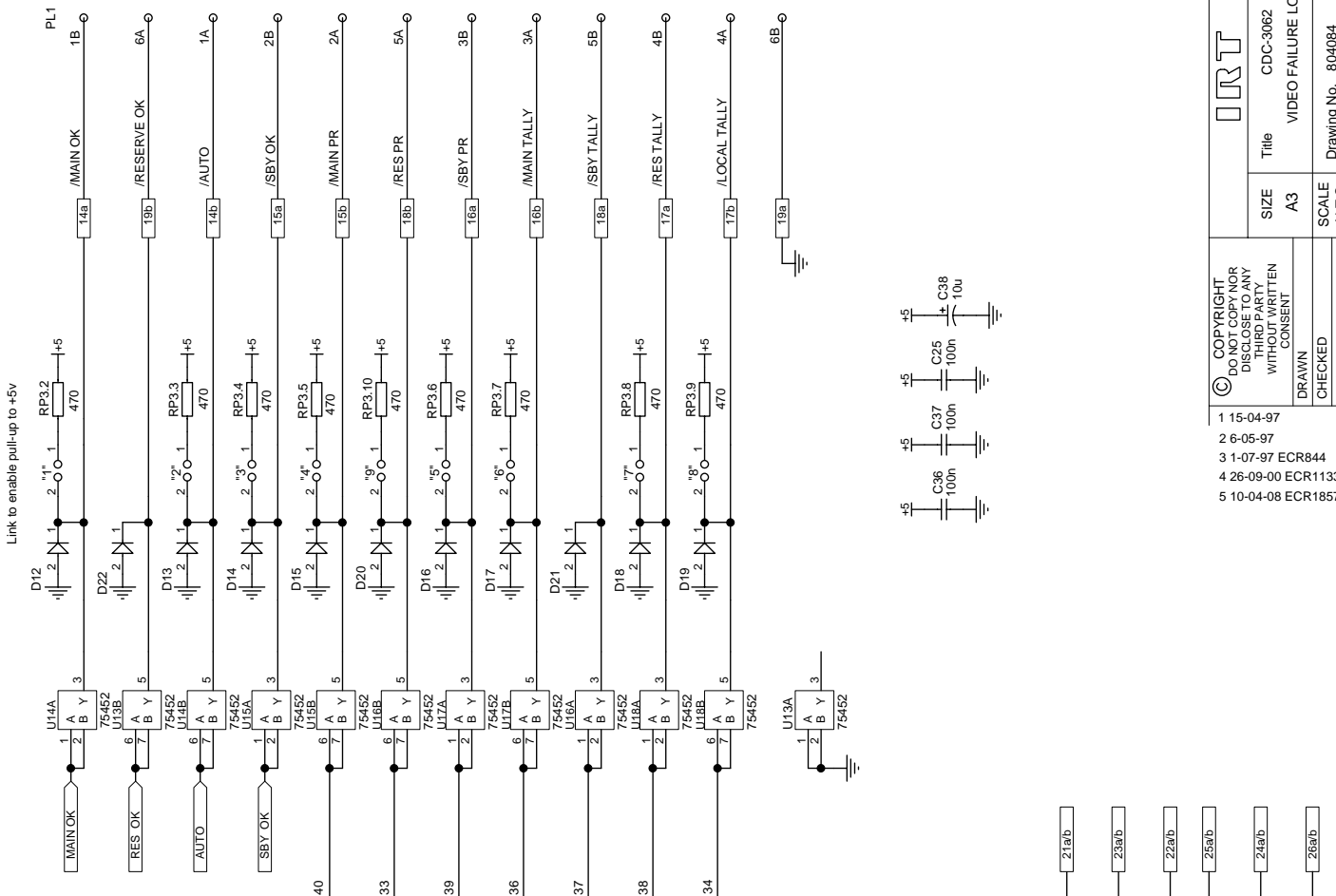

Link to enable pull-up to +5v

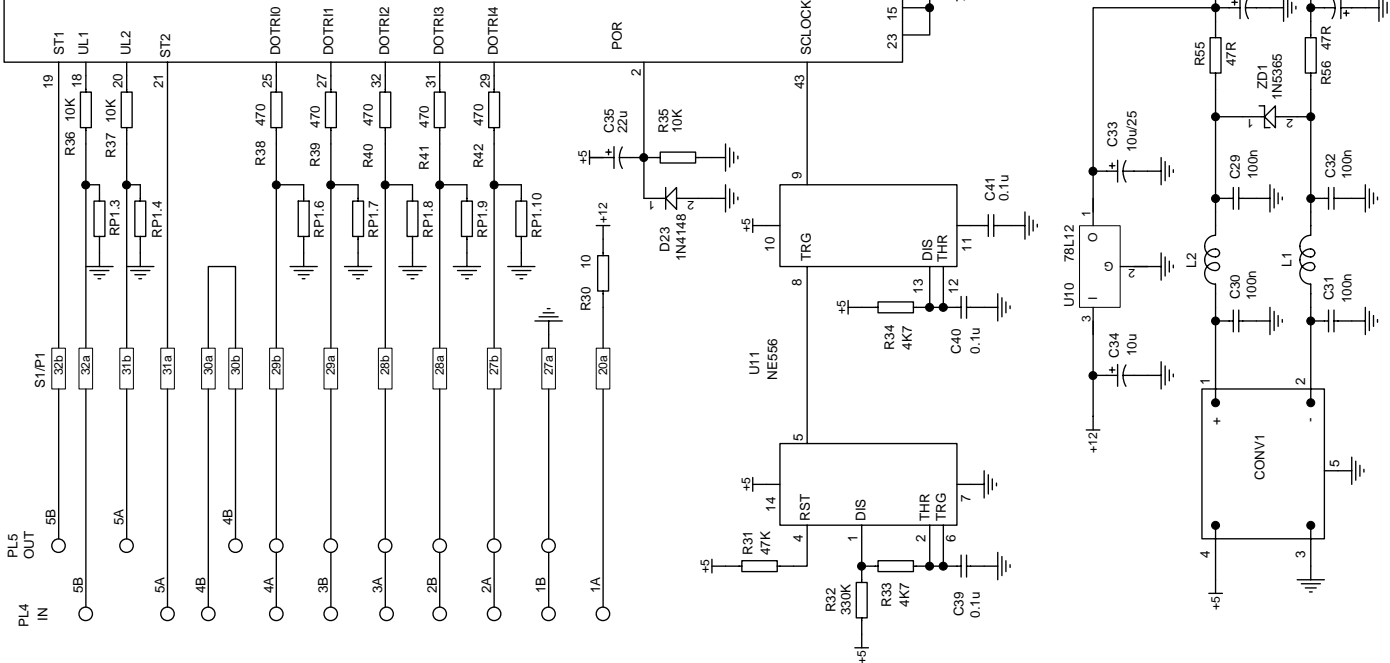
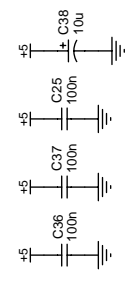

1 15-04-97
 2 6-05-97
 3 1-07-97 ECR844
 4 26-09-00 ECR1133
 5 10-04-08 ECR1857

COPYRIGHT
 DO NOT COPY NOR
 DISSEMINATE
 WITHOUT WRITTEN
 CONSENT
 DRAWN
 CHECKED
 ENG. APP.
 Revision: 5
 Date: 2-May-2008

IRT
 Title CDC-3062
 VIDEO FAILURE LOGIC
 SIZE A3
 SCALE N.T.S.
 Drawing No. 804084
 IRT Electronics Pty. Ltd.
 ARTARMONNSW AUSTRALIA 2064

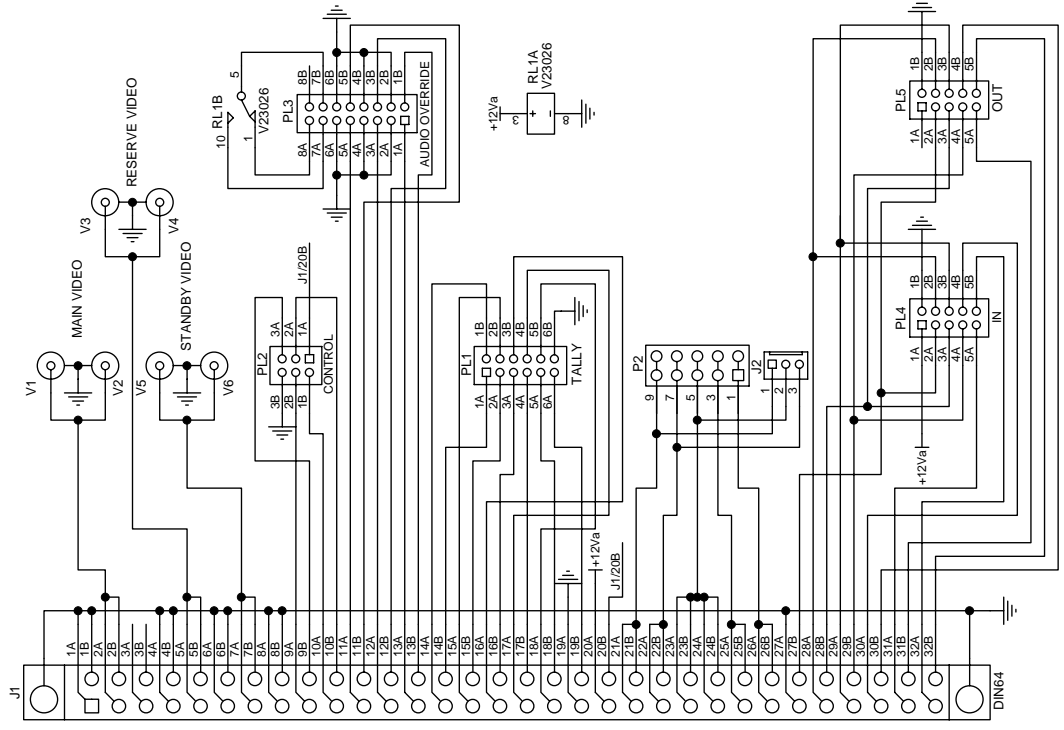

REMOTE CONTROL INTERFACE

		Title		Sheet	
		CDC-3062ra		3 of 3	
Size		Drawing No.		Title	
A3		804084		Video Failure Logic	
Scale		Drawing No.		Sheet	
N.T.S.		804084		3 of 3	
Checked		Revision:		Drawing No.	
K.N.		5		804084	
Drawn		Date:		Drawing No.	
K.N.		2-May-2008		804084	
Checked		Date:		Drawing No.	
ENG. APP.		2-May-2008		804084	
Revision:		Date:		Drawing No.	
5		2-May-2008		804084	
08-04-2008		Date:		Drawing No.	
ECR1857		2-May-2008		804084	
Copyright		Date:		Drawing No.	
Do not copy nor		2-May-2008		804084	
reproduce or		Date:		Drawing No.	
transmit in		2-May-2008		804084	
any form		Date:		Drawing No.	
without		2-May-2008		804084	
written		Date:		Drawing No.	
consent		2-May-2008		804084	
Checked		Date:		Drawing No.	
K.N.		2-May-2008		804084	
Drawn		Date:		Drawing No.	
K.N.		2-May-2008		804084	
Checked		Date:		Drawing No.	
ENG. APP.		2-May-2008		804084	
Revision:		Date:		Drawing No.	
5		2-May-2008		804084	
08-04-2008		Date:		Drawing No.	
ECR1857		2-May-2008		804084	