



**I R T Electronics Pty Ltd A.B.N. 35 000 832 575**  
26 Hotham Parade, ARTARMON N.S.W. 2064 AUSTRALIA  
National: Phone: (02) 9439 3744 Fax: (02) 9439 7439  
International: +61 2 9439 3744 +61 2 9439 7439  
Email: [sales@irtelectronics.com](mailto:sales@irtelectronics.com)  
Web: [www.irtelectronics.com](http://www.irtelectronics.com)

## **IRT FRU-4001 3RU Eurocard Frame with SNMP Control & Power Supplies**

### **Types FRU-4001**

**PSU-4001**

**PSU-4101**

**CDM-4001**

**SMU-4000**

**Designed and manufactured in Australia**

**IRT can be found on the Internet at:  
<http://www.irtelectronics.com>**



# IRT FRU-4001 3RU Eurocard Frame with SNMP Control & Power Supplies

## Types FRU-4001

**PSU-4001**

**PSU-4101**

**CDM-4001**

**SMU-4000**

## Instruction Book

### Table of Contents

Section	Page
Revision History	2
Operational Safety	4
FRU-4001 3 RU Eurocard frame	5
FRU-4001 General Description	5
FRU-4001 Technical Specifications	6
FRU-4001 Circuit Description	7
FRU-4001 Installation	8
Power Supply Module	8
CDM-4001 SNMP Agent Module	8
Eurocard Module	9
EMC	9
FRU-4001 Front and rear location diagrams	10
PSU-4001 General Description	11
PSU-4001 Technical Specifications	11
PSU-4001 Circuit Description	12
PSU-4001 Pre-installation	12
Earthing	12
PSU-4001 Installation	13
Performance	13
PSU-4001 Front & rear panel connector diagrams	14
PSU-4101 General Description	15
PSU-4101 Technical Specifications	15
PSU-4101 Circuit Description	16
Pre-installation	16
Earthing	17
Operational Safety	17
Installation & Servicing	18
Front & rear panel diagrams	19
CDM-4001 General Description	20
CDM-4001 Technical Specifications	21
CDM-4001 Installation	22
CDM-4001 Front & rear panel connector diagrams	23
CDM-4001 Setup	24
SMU-4000 General Description	26
SMU-4000 Installation	27
Figure 1: SMU-4000 module	27
SNMP – What Is It?	28
Maintenance & Storage	30
Warranty & Service	30
Equipment return	30

This instruction book applies to units later than S/N 0801001.

## Operational Safety:

### WARNING

Operation of electronic equipment involves the use of voltages and currents that may be dangerous to human life. Note that under certain conditions dangerous potentials may exist in some circuits when power controls are in the **OFF** position. Maintenance personnel should observe all safety regulations.

Do not make any adjustments inside equipment with power **ON** unless proper precautions are observed. All internal adjustments should only be made by suitably qualified personnel. All operational adjustments are available externally without the need for removing covers or use of extender cards.

### WARNING

#### AC Power Supplies

Whilst every effort has been made to prevent exposure of service personnel to dangerous voltages, AC mains input power supplies are by their nature dangerous when connected to the AC mains supply.

Wherever possible maintenance work on power supplies should be carried out with the mains input disconnected - NOT just switched off.

When testing units with the mains supply ON, the supply should be connected through an earth leakage circuit breaker and should not be done without another person in attendance.

## IRT Eurocard Frame

### Type FRU-4001

### General Description

The purpose of the FRU-4001 is to provide an economical and compact mechanical framing system for IRT Eurocards. Provision is made for two power supplies to be fitted for power supply redundancy.

Each supply is capable of supplying 50 VA of power continuously or 80 VA of power for a short period with reduced mains voltage variations. Most IRT modules require less than 5 VA each.

With two power supplies fitted a total of 10 standard IRT Eurocards can be accommodated in one standard IRT FRU-4001 3 Rack Unit Frame. If only one supply is used the second power supply rear assembly can be removed to increase the number of Eurocard positions to 12.

The FRU-4001 frame also has provision for the addition of a Simple Network Management Protocol (SNMP) card, the CDM-4001, to act as an "Agent" when used with a third party Network Management System. This card has its own slot position and does not affect the number of modules that can be installed in the frame.

In order for SNMP to be effective, as well as having a CDM-4001 Agent card installed, the installed modules must themselves be fitted with either the optional SMU-4000 plug in board programmed with its relevant Management Information Base (MIB), or be loaded with its own SNMP firmware upgrade (where applicable).

The frame provides a power supply bus to reticulate power from one or two common low voltage power supply units to all cards in the frame. It also provides a data bus for SNMP control when the frame is fitted with a CDM-4001 SNMP Agent card (sold separately). Ethernet connection is via an RJ45 connector on the rear of the standard supplied power supply rear assembly.

IRT Eurocard products are supplied in two parts; an *electronics module* complete with front fascia panel and a *rear assembly*, which provides the necessary connections to other equipment.

The *electronics module* and *rear assembly* are fitted with multipin mating connectors allowing them to be connected directly together.

The *rear assembly* is screwed to the rear of the frame with pins mating to the frame's power supply bus and SNMP control bus.

The *electronics module* can be inserted or removed from the frame from the front. When inserted it mates directly with the *rear assembly*.

This method generally allows the *electronics module* to be inserted or removed without disturbing any wiring connected to the *rear assembly*. (In the case of particular modules, such as optical fibre modules, special connections may either prevent this or require special care. Please consult installation instructions for particular modules for details).

An extender card may be used to allow servicing of the module whilst it remains connected to the frame, except in the case of SNMP operation.

The FRU-4001 frame will take all IRT 4000 series Eurocards as well as current 700 and 3000 series Eurocards that have the correct type of power connector on the rear assembly.

## Technical Specifications

### IRT Eurocard Frame Type FRU-4001

#### Power:

Note: FRU-4001 requires either one or two AC or DC power supplies to be installed.

Input power: AC AC mains input (110 Vac, 130 Vac, 220 Vac or 240 Vac  $\pm 10\%$ )  
and / or

DC -48 Vdc  $\pm 25\%$  (if DC power supply installed)

Input power fuses AC SLO-BLO 500 mA for 240 Vac  
SLO-BLO 1000 mA for 110 Vac

DC Fused in -48 Vdc PSU module.

Output power to module bus: AC 28 Vac CT (14-0-14) from AC PSU module.  
and / or

DC  $\pm 16$  Vdc from -48 Vdc PSU module.

#### Connectors:

Module rear assembly to frame Power CLT105-02FDBE-A 10 pin SMD connector, bottom entry.  
SNMP CLT103-02FDBE-A 6 pin SMD connector, bottom entry.

SNMP control RJ45 Ethernet connector.

SNMP Agent RS232 9 pin female D connector.

Power module to frame H15FP4 H15 female 4 mm PCB mounting.

Power input to frame AC IEC 320 with integral fuse holder.

DC 3-pin termination block.

Alarm output Centre pin of DC supply input 3-pin termination block of PSU-A rear assembly.

#### Other:

Temperature range 0 - 50° C ambient.

Mechanical 3 RU (482 mm x 132 mm) standard 19" rack frame.  
Suitable for mounting in standard 19" racks.

Finish: Natural anodised aluminium frame with passivated steel rear power connection box with black silk-screened lettering.

Dimensions 482 x 132 x 253 mm (Frame empty.)  
Clearance width 445 mm

Optional accessories TME-6 module extender card for Eurocard modules.  
PSU-4001 voltage selectable power supply module.  
PSU-4101 -48Vdc power supply module.  
CDM-4001 SNMP Agent module.  
SMU-4000 SNMP plug-in MIB board for modules housed in frame.

**Due to our policy of continuing development, these specifications are subject to change without notice.**

## Circuit Description

The FRU-4001 frame can distribute to each module two low voltage centre tapped power supplies. One supply is fitted into slots 13 and 14 (hereby designated as main supply, or PSU-A), the second power supply (herby designated as secondary supply, or PSU-B) fitted into slots 11 and 12. The use of two supplies gives complete power supply redundancy. When a frame is fitted with two supplies any one supply can be temporarily removed without causing interruptions.

Normally the supplies would be PSU-4001 AC supplies but can optionally be PSU-4101 DC supplies. When PSU-4001 AC power supplies are used, the two supplies distributed are both 28Vac, centre tapped. When two PSU-4101 DC power supplies are used, the two supplies are both + and – 16Vdc. All IRT modules will operate with either of these supplies.

Failure of each supply is reported to the optional CDM-4001 SNMP agent module. This module, in addition to raising an SNMP trap, will indicate the failure by switching a relay to ground. This contact is available on the centre pin (labelled Alarm) of a three-pin connector of the main supply rear assembly (PSU-A) on the rear of the frame. The alarm condition will only occur with a CDM-4001 card fitted to the frame and either the failure of one of the supplies or the power feed to the supply. Physically removing a supply from the frame will not cause an alarm condition to occur.

## Installation

### Power Supply Module

The frame will operate with either one or two power supply modules installed.

The power supply modules slide in from the front of the frame via guides in the Eurocard slot positions 13/14 or 11/12 at the right hand end of the frame. The four retaining screws on the front should be tightened.

Connect power input to rear of frame. For DC input, observe the polarity markings next to each connector.

Due to its weight if the frame is to be freighted for any purpose the power supply should be removed and packed separately before shipment.

If only 1 power supply is to be fitted and the frame to be used for 12 Eurocard modules, remove the 2nd power supply rear assembly (PSU-B) allowing Eurocard slot positions 11 & 12 to become available.

### CDM-4001 SNMP Agent Module

If the FRU-4001 frame is to be fitted with SNMP capability, then the CDM-4001 SNMP Agent module needs to be installed.

Looking at the front view of the FRU-4001 frame, remove the main power supply from slot positions 13/14. The main power supply front panel covers over the CDM-4001 slot position (slot 15) at the very right end of the frame.

In order to fit the CDM-4001 SNMP agent module the main power supply front panel needs to be replaced with the narrower front panel (supplied together with the CDM-4001 module) by removing the 4 mounting screws off the front panel of the power supply. Swap over the handle from the original supply front panel to the narrower panel and then attaching the narrower panel to the supply by the same 4 mounting screws.

Slide the CDM-4001 module into the slot 15 guides all the way until the module mates with the 96-pin connector at the rear of the frame, and then tighten the two front retaining screws. Once the CDM-4001 card has been installed, re-install the main power supply fitted with the narrower front panel.

Signal connections to this card are via the rear of the frame below the IEC mains plug input. The 9 pin female D9 connector is an RS-232 interface for connection to a computer for initial setup parameters of the frame for SNMP use. The RJ45 connector is for Ethernet connection.

## Eurocard Module

In order for an IRT Eurocard to be mounted within the FRU-4001 frame, the rear assembly must be fitted with power pins to pick up power from the frame power bus. All IRT 4000 series cards come fitted with these pins and are fully compatible with the FRU-4001 frame as are current 700 and 3000 series Eurocard modules that have the correct type of power connector on the rear assembly. Older versions of 700 and 3000 series Eurocard modules that do not have the power pins on the rear assembly are not compatible with the FRU-4001 frame.

Ensure that the rear assembly has the correct orientation and carefully align the power pins and SNMP pins over power and SNMP bus connectors. With equal pressure to the top and bottom of the rear assembly, press until the rear assembly PCB touches the frame mounting rails at the top and bottom. Install the two retaining screws (Metric M2.5 x 10 mm).

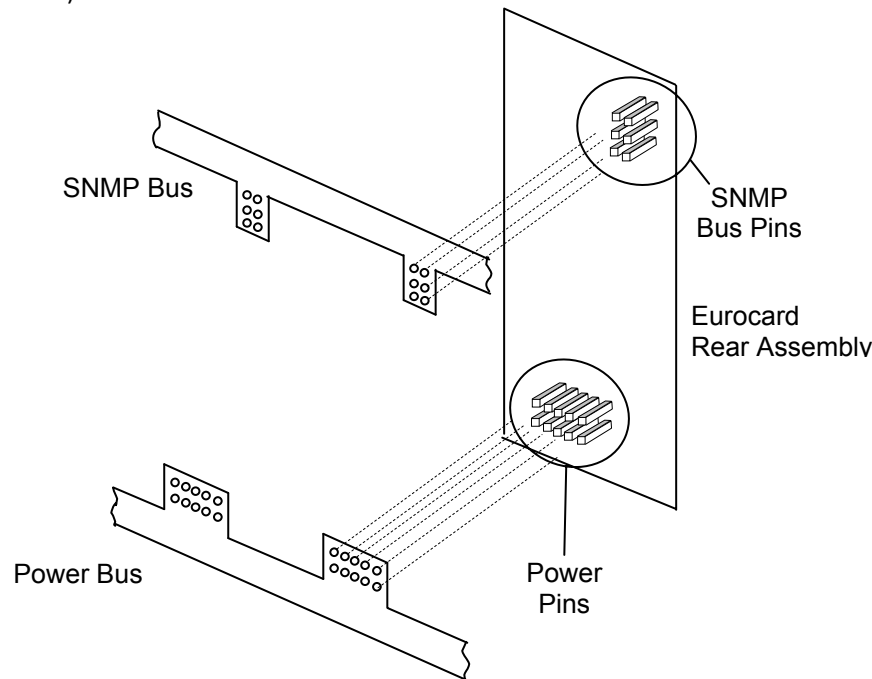

Rear assemblies may be removed for maintenance. Make sure that extraction force is applied equally and steadily at the top and bottom of the rear assembly simultaneously.

**If extraction force is not equally applied, there is a good chance that the module connector pins will be bent, making it very difficult to re-install the rear assembly.**

Slide the Eurocard module into the front of the frame in the guides corresponding to the position of the installed mating rear assembly until it makes mating contact with the rear assembly 64 pin connector, then tighten the two front retaining screws.

### Warning

#### Optical Connections

The optical connectors on modules may be attached to the main module PCB, NOT the rear connector assembly.

When installing the optical fibre sufficient slack should be allowed for the module to be withdrawn with the optical fibre attached until the connector is clear of the frame and can be disconnected.

If this is not done, the module will not be able to be removed without first disconnecting the optical fibre at the rear. Attempting to remove the module without first disconnecting the fibre may result in damage to the fibre and / or the module.

## EMC

Due to EMC (electromagnetic compliance) standards, IRT recommends that all unused card positions be closed off using IRT front blanking panels, on the front, and rear blanking panels, on the rear, of the frame.

**Front & rear location diagrams**

The following front panel and rear assembly drawings are not to scale and are intended to show connection order and approximate layout only.

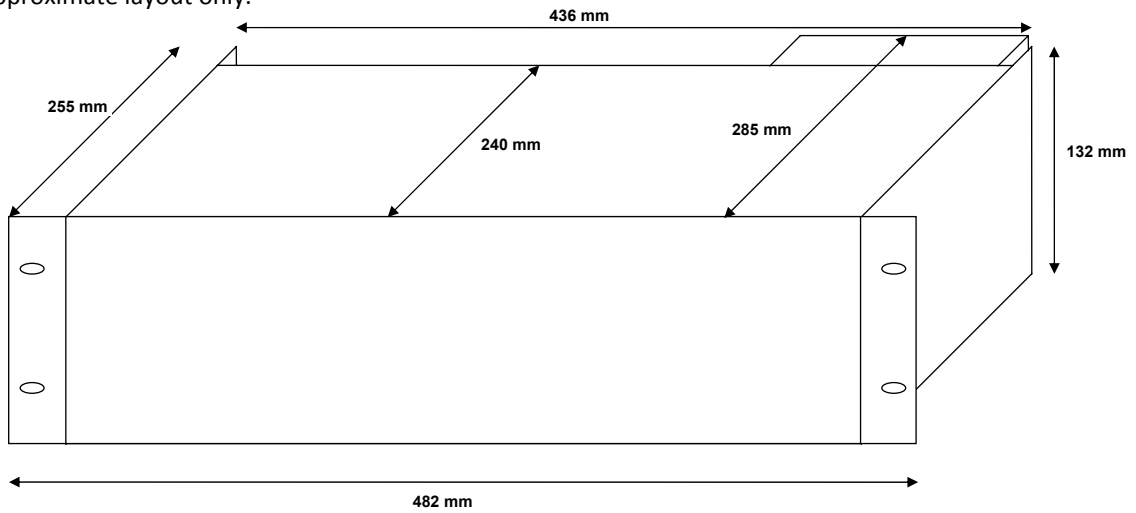

**FRU-4001 with one PSU fitted - Front View**

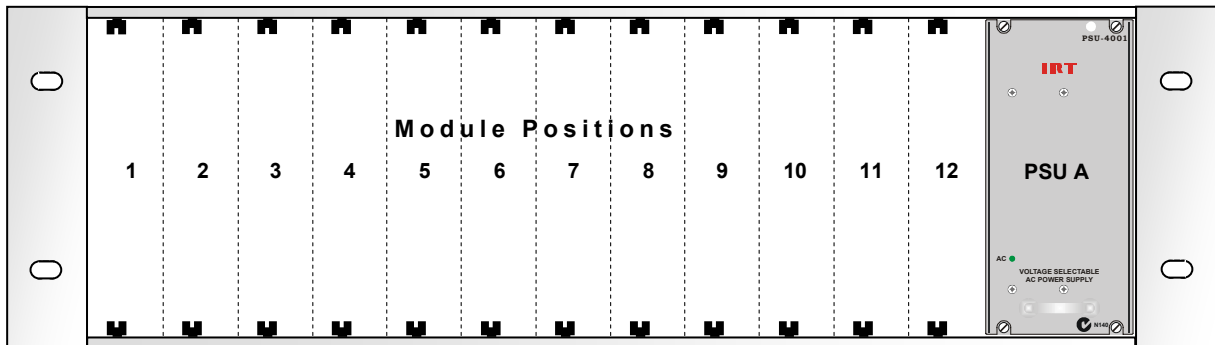

**FRU-4001 with 2nd PSU and CDM-4001 "SNMP Agent" card fitted - Front View**

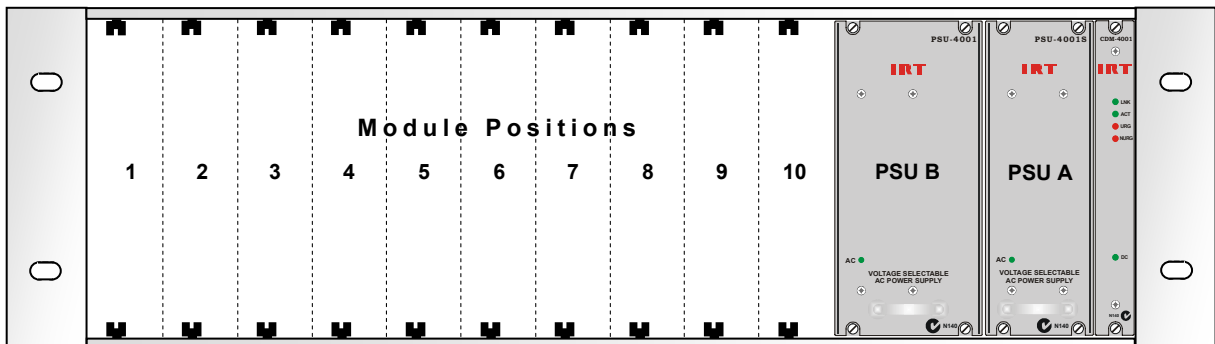

**FRU-4001 (Standard) - Rear View**

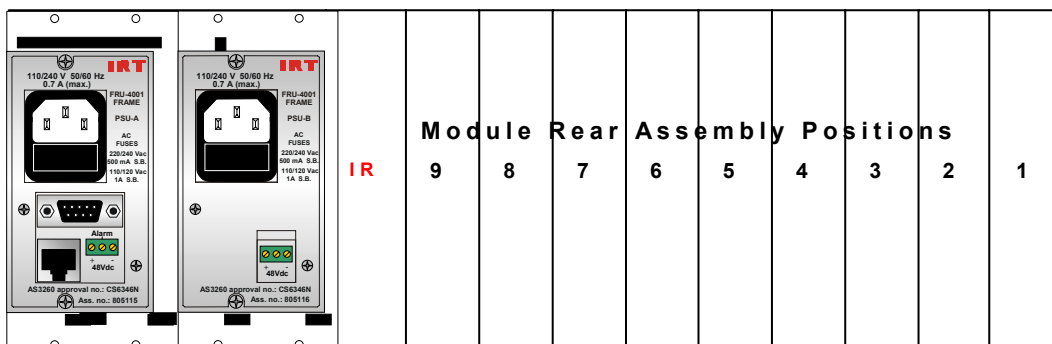

## IRT Power Supply for Eurocard

### Type PSU-4001

#### General Description

The PSU-4001 is designed to provide the low voltage AC power required for operation of up to 12 standard IRT Eurocard modules fitted within an IRT FRU-4001 frame. The PSU-4001 adds the facility of providing for selection of the AC mains input voltage by way of a selector switch on the side of the PSU.

Two PSU-4001's can be operated redundantly when using an IRT FRU-4001 frame. The redundant power supply facility of the PSU-4001 is enabled in each IRT Eurocard module by having the power supply circuit of each module made up of two bridge rectifier circuits with the outputs connected in parallel. This allows the 28 Vac CT voltages to be sourced from either PSU-4001.

A front panel LED indicator provides visual confirmation of the presence of the low voltage output.

An alarm relay is also included which will activate the alarm in the SNMP controller module, if fitted, if either side of the AC output fails.

A voltage selector switch allows the PSU-4001 to be configured for 240V, 220V, 130V or 110V operation.

### Technical Specifications

#### IRT Eurocard Dual Power Supply Module

#### Type PSU-4001

##### Power Requirements:

Voltage	240 Vac $\pm$ 10%
	220 Vac $\pm$ 10%
	130 Vac $\pm$ 10%
	110 Vac $\pm$ 10%
Frequency	45 - 65 Hz $\pm$ 10%
Fusing	500 mA anti-surge for 240V and 220V operation, 1000 mA anti-surge for 130V and 110V operation. Fuses are installed in the associated rear assembly.

**Standards Approval:** AS3260 approval no.: CS6346N

**Output:** 28 Vac centre tapped (14 - 0 - 14) fully loaded.  
80 VA maximum.

##### Connectors:

AC power input / AC output H15MFAV32 male, Faston

##### Other:

Temperature range 0 - 50° C ambient

Mechanical Suitable for mounting in FRU-4001 rack frame

Finish: Front panel Grey background, black lettering & red IRT logo  
Body Passivated steel with silk-screened black lettering.

Dimensions 6 HP x 3 U x 230 mm

**Due to our policy of continuing development, these specifications are subject to change without notice.**

## Circuit Description

The PSU-4001 consists of a power transformer, which provides a 28 Vac centre tapped output.

All connections to the module are made via a single multipin connector. Extreme care should be taken when working in the vicinity of this connector as it carries the live mains input voltage.

The front panel LED power indicator is supplied from the output with the full 28 Vac via a rectifier diode and series resistor.

The alarm is powered from the output rails, in parallel with the LED indicator. The use of the alarm requires an SNMP controller card within the FRU-4001 frame.

When operating normally the alarm is open circuit. When a supply is lost the alarm line is grounded.

### Pre-Installation:

#### Handling:

This equipment may be connected to static sensitive devices and proper static free handling precautions should be observed when disconnecting or reconnecting either the input or the output of the PSU.

#### Power:

Set the Voltage selector switch for the correct input Mains voltage. Ensure that the correct fuses are installed in the associated rear assembly – 1000 mA anti-surge for 130 and 110V and 500 mA anti-surge for 220 and 240V operation.

#### Earthing:

##### Supply earth:

For safety reasons a connection is made between the IEC connector earth pin and the IRT FRU-4001 chassis. No attempt should be made to break this earth connection.

When the PSU-4001 is installed in the IRT FRU-4001 frame a connection will be made between the above earth and the PSU-4001 chassis.

##### Power supply output earth:

No connection is made between the centre tap of the PSU-4001 low voltage output and the chassis frame.

##### Signal earth:

##### FRU-4001 frame:

The signal earth of all IRT modules is connected to the chassis frame.

## PSU-4001 Installation

**The PSU-4001 contains no user serviceable parts inside and should not be opened.**

**In the event of failure of the supply, the input operating voltage and IEC input connector fuse should be checked.**

**If fault persists the complete unit should be returned to IRT or your local agent for service.**

### Performance:

One PSU-4001 is designed to provide adequate power for an FRU-4001 frame equipped with its maximum of twelve Eurocard modules under normal conditions. During normal operation, this power is shared between two supplies mounted in the frame with a maximum of ten Eurocard modules.

This performance is contingent on two power supplies being operational and the AC mains supply input being within the specified range.

Where both an AC and DC supply are fitted in the one frame, the degree of load sharing will be dependent on the AC input voltage to the PSU-4001. This will directly affect its output voltage whereas the DC supply will continue to supply a constant voltage output over a wide range of input voltages.

If only one supply is operational or the AC supply voltage to one supply is low, module performance may be affected.

The provision of two power supplies is intended to provide continued operation, during failure of one supply, until the second supply can be restored.

If the AC mains supply input is subject to wide fluctuation, a suitable stabilised source should be installed.

### FRU-4001 Frame:

The PSU-4001 should be slid firmly into either of the two double width slots (11/12 & 13/14) at the right of the frame. The four retaining screws on the front should then be tightened.

Power to the PSU-4001 is supplied from a connector located on the rear of the FRU-4001, immediately to the rear of the module.

Note that the IEC320 connectors have inbuilt fuses. A spare fuse may also be stored inside the connector. The fuse should 1000 mA anti-surge for 130 and 110V operation and 500 mA anti-surge for 240 and 220V operation.

The alarm output connector is located on the rear of the FRU-4001 frame and is common to both supply units when installed. The alarms for both units are in parallel such that when a fault develops in either PSU the alarm output will be grounded.

Due to its weight the PSU-4001 can be damaged itself or cause damage to the frame if subjected to a large mechanical shock.

**If the frame is to be freighted for any purpose, remove the PSU-4001 and pack separately before shipment taking care to ensure that protruding edges of front fascia panel are well protected.**

**For this purpose we recommend the use of plastic bubble packaging.**

### Front & rear panel connector diagrams

The following front panel and rear assembly drawings are not to scale and are intended to show relative positions of connectors, indicators and controls only.

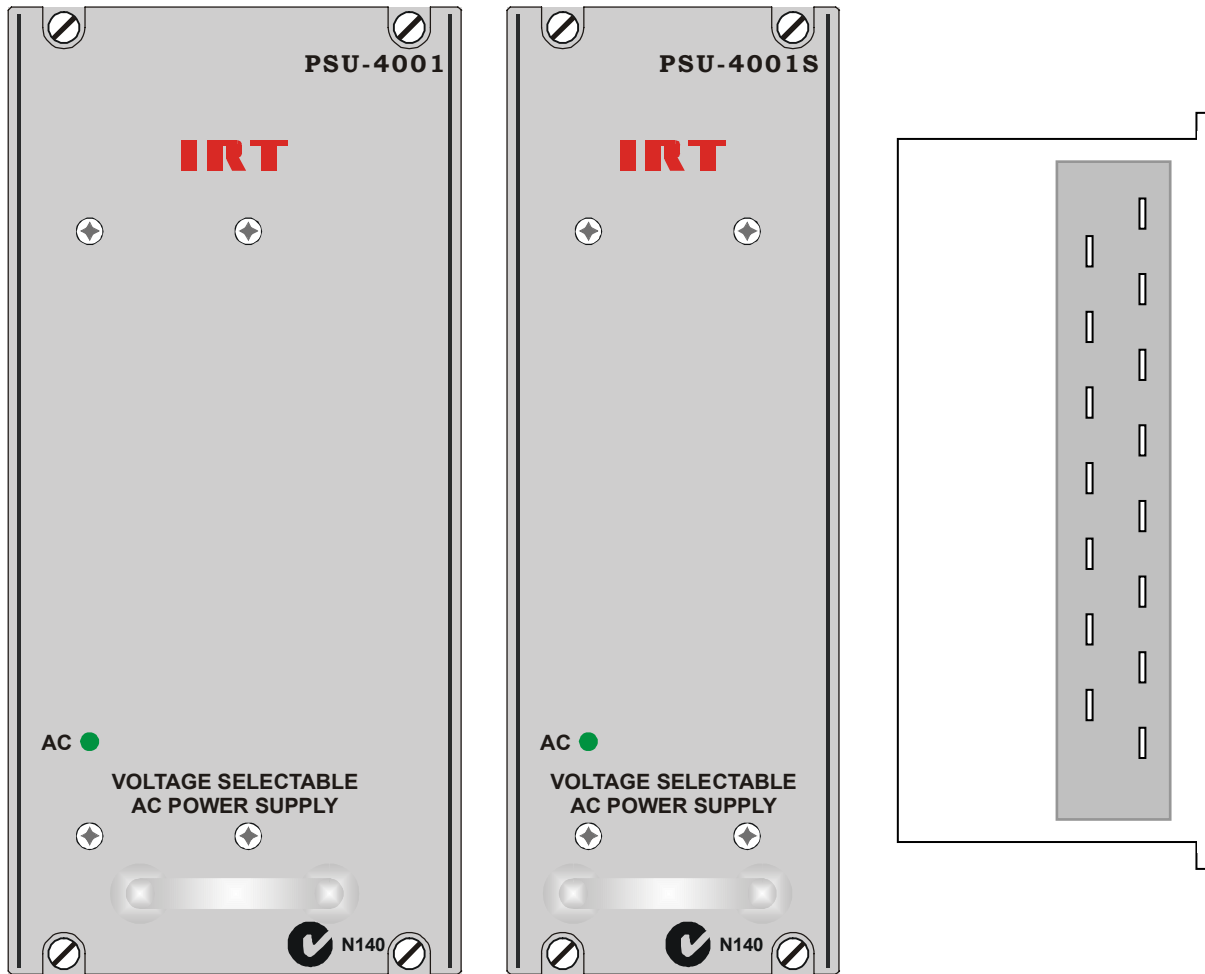

Supplied standard width front panel

Narrow width front panel for use when SNMP controller fitted.



## Circuit Description

The PSU-4101 consists of two DC-DC converter circuits, each of which provides a 16 Vdc output. The inputs are wired in parallel and the outputs differ only in the grounding of the positive or negative output of the converter.

The DC input circuitry consists of a safety fuse followed by a low value series resistance and overvoltage protection zener diode and a number of RF suppression components.

The front panel LED power indicator and alarm relay are powered from the output rails by way of a series 15 Volt zener diode. If either rail fails there is insufficient voltage to operate the relay and the LED dims sufficiently to indicate the fault condition.

When operating normally the alarm is open circuit. When supply is lost the alarm line is grounded. The use of the alarm requires an SNMP controller card within the FRU-4001 frame.

### Pre-Installation:

#### Handling:

This equipment may be connected to static sensitive devices and proper static free handling precautions should be observed when disconnecting or reconnecting either the input or the output of the PSU.

#### Power:

Ensure that operating voltage of unit and local DC supply voltage match, and that the polarity is correctly wired.

**Earthing:****Supply earth:**

For safety reasons, a connection is made between the IEC connector earth pin, the DC input connector +ve pin and the FRU-4001. No attempt should be made to break this earth connection.

When the PSU-4101 is installed in the FRU-4001 frame a connection will be made between the above earth and the PSU-4101 chassis. This earth is also connected to the centre tap output connection of the PSU-4101.

**Power supply output earth:**

A connection is made between the output common connection of the PSU-4101 and chassis ground within the PSU-4101.

**Signal earth:****FRU-4001:**

When the rear assembly of a module is connected to the FRU-4001 frame, the signal earth of that rear assembly may or may not be connected to the chassis depending on the particular rear assembly design.

Power supply connections on the rear assembly are not connected to the signal earth on the rear assembly.

When a module is inserted into the FRU-4001 frame, a connection is made between the PSU-4101 power supply ground and signal earth. Depending on the particular module design, the signal earth may be connected to the front panel of the module and may therefore make a connection to the FRU-4001 frame via the front securing screws.

This results in a central earth point on each module for power supply and signal.

**General:**

If a "technical" earth is required for the system, this may be connected to the rack, frame and signal earth according to the requirements of each individual installation. For connection to the signal earth refer to details of connections for particular modules installed in the frame.

**Operational Safety:****WARNING**

Operation of electronic equipment involves the use of voltages and currents that may be dangerous to human life. Note that under certain conditions dangerous potentials may exist in some circuits when power controls are in the **OFF** position. Maintenance personnel should observe all safety regulations.

Do not make any adjustments inside equipment with power **ON** unless proper precautions are observed. All internal adjustments should only be made by suitably qualified personnel. All operational adjustments are available externally without the need for removing covers or use of extender cards.

## Installation & Servicing

**The PSU-4101 contains no user serviceable parts inside and should not be opened.**

**In the event of failure of either output, the input operating voltage and front panel input fuse should be checked.**

**If fault persists the complete unit should be returned to IRT or your local agent for service.**

### Performance:

One PSU-4101 is designed to provide adequate power for an FRU-4001 frame equipped with its maximum of ten Eurocard modules under normal conditions. During normal operation, this power is shared between the two supplies mounted in the frame.

This performance is contingent on two power supplies being operational and the AC mains supply input being within the specified range.

Where both an AC and DC supply are fitted in the one frame, the degree of load sharing will be dependent on the AC input voltage to the AC supply. This will directly affect its output voltage whereas the DC supply will continue to supply a constant voltage output over a wide range of input voltages.

Where two PSU-4101's are fitted in the one frame, the degree of load sharing will be dependent on the match in output voltages between the two supplies.

If only one supply is operational or the AC supply voltage to one supply is low, module performance may be affected.

The provision of two power supplies is intended to provide continued operation, during failure of one supply, until the second supply can be restored. Continuous single supply operation is not recommended.

### FRU-4001 Frame:

The PSU-4101 should be slid firmly into either of the two double width slots (11 & 12) at the right of the frame. The four retaining screws on the front should then be tightened.

Power to the PSU-4101 is supplied from a connector located on the rear of the FRU-4001, immediately to the rear of the module. Care should be taken to observe the correct polarity as marked when connecting DC to this connector.

The alarm output connector is located on the rear of the FRU-4001 frame and is common to both supply units when installed. The alarms for both units are in parallel such that when a fault develops in either PSU the alarm output will be grounded. The use of the alarm requires an SNMP controller card within the FRU-4001 frame.

**WARNING** - Each PSU-4101 dissipates up to 6 Watts and a full frame of ten VA-700's and two PSU-4101's dissipates up to 66 Watts. Ensure that adequate ventilation is available to keep down the operating temperature. If possible, at least 44.5 mm (1 RU) should be left clear above each frame.

### Internal adjustments:

The PSU-4101 is factory set for the correct output voltages and should not require re-adjustment unless one of the DC - DC converters is replaced.

Adjust RV 1 for -16 Vdc

Adjust RV 2 for +16 Vdc

**Front & rear panel diagrams**

The following front panel and rear assembly drawings are not to scale and are intended to show relative positions of connectors, indicators and controls only.

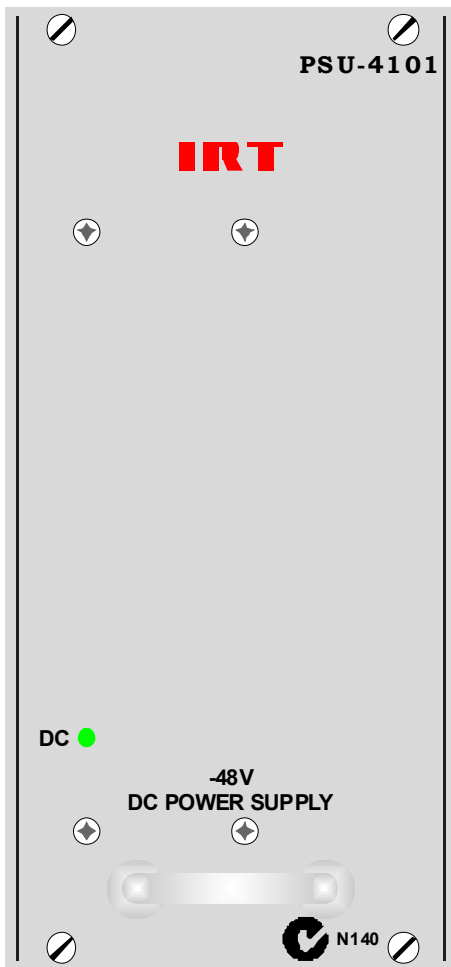

Standard Front Panel

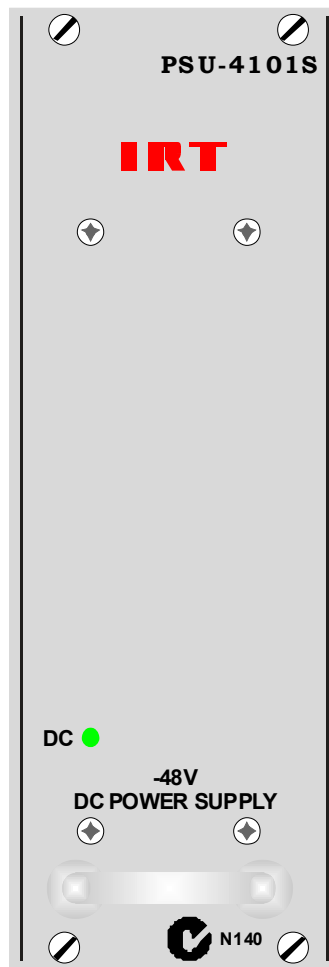

Narrow Front Panel  
(when used in conjunction with CDM-4001)

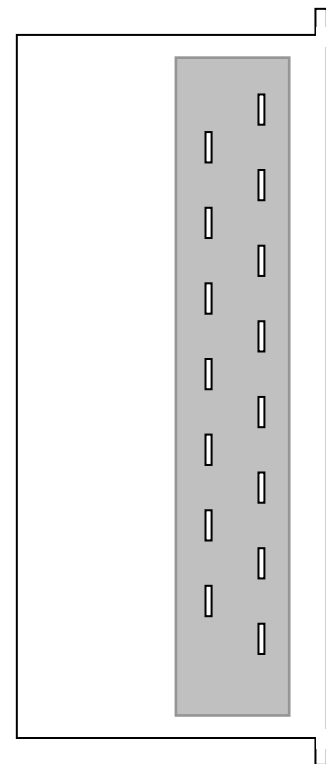

Rear View

## **SNMP Agent Frame Controller Type CDM-4001**

### **General Description**

The CDM-4001 is a Simple Network Management Protocol (SNMP) Agent for use in IRT's FRU-4001 3RU frame. It occupies its own designated slot within the frame, next to the power supply, so it does not affect the number of modules that can be used within the frame.

The CDM-4001 can communicate with all modules in a Frame that are fitted with an SMU-4000 SNMP Interface sub-board, or have inbuilt SNMP facilities. The information obtained is forwarded via an Ethernet connection to any SNMP Network Management System (NMS) whose address is configured in the CDM-4001.

The CDM-4001 holds parameters such as Frame Name, Address and Location. This information may be set via an RS232 Configuration port.

The NMS third party software (not supplied by IRT) polls the CDM-4001 to remotely monitor and control the frame and its SNMP capable modules.

In the event of a major alarm from any of the modules or power supply an alarm condition, known as a Trap, is automatically sent without any prompting from the NMS.

Front panel LEDs indicate the presence of an Ethernet link, link activity and the Frame urgent & non-urgent alarm states.

Ethernet connection is via an RJ45 connector and the RS232 is via a D9 female connector on the rear of the frame. Modules that are being monitored and controlled share a common data bus on the frame.

SNMP monitoring and control finds particular use in remote or unmanned locations such as transmitter sites, or where control via a computer is desired.

As the CDM-4001 can be assigned its own IP Address, multiple sites can be monitored and controlled via the one NMS. Alternatively, multiple NMS's in different locations can be used to monitor and control the same site.

### **Features:**

- **SNMP remote monitoring and control via Ethernet connection**
- **Automatic "Trap" transmission on major alarms**
- **Front panel LED indicators**
- **Own designated slot in the FRU-4001 3RU frame**

## CDM-4001 Technical Specifications

### Ethernet:

Rate 100baseT\ 10 baseT.  
Connector RJ45 (on rear of 4000 series frame).

### RS232:

Rate 9600 baud  
Connector Female D9  
(on rear of FRU-4001 frame)

### SNMP:

Version 1  
Configurable settings sysContact  
sysName  
sysLocation  
Agent IP address  
NMS IP address (max 5)  
Gateway IP address  
Subnet mask  
Community  
Agent port number  
Trap port number

### Front Panel Indicators:

LINK (Green) - Ethernet present  
ACT (Green) - Activity, Ethernet communication  
URG (Red) - Urgent Alarm detected  
NURG (Red) - Non urgent Alarm detected  
DC (Green) - Power present

Power Requirements 28 Vac CT (14-0-14) or  $\pm 16$  Vdc.

Power consumption <5 VA.

### Other:

Temperature range 0 - 50° C ambient.

Mechanical Suitable for mounting in IRT 19" rack chassis with input, output and power connections on the rear panel.

Finish: Front panel Grey background, black lettering.  
Rear assembly Part of the FRU-4001 3RU frame.

Dimensions 3 HP x 3 U x 220 mm IRT Eurocard

**Due to our policy of continuing development, these specifications are subject to change without notice.**

## CDM-4001 Installation

If the FRU-4001 frame is to be fitted with SNMP capability, then the CDM-4001 SNMP Agent module needs to be installed.

The CDM-4001 occupies its own designated spot to the very right of the FRU-4001 frame. Remove the power supply from the frame and slide the CDM-4001 into position.

A narrower width front panel for the AC power supply is supplied with the CDM-4001. The standard power supply comes equipped with a 60mm width front panel that normally covers the CDM-4001 slot. With the CDM-4001 in place it is necessary to change the front panel of the power supply that sits directly next to the CDM-4001 card with the supplied narrower width front panel. Four screws hold the front panel in place to the power supply. Remove the four screws to take the front panel off the supply. Swap the front panel handle over to the narrower width panel and attach the narrower front panel to the supply with the same four screws. The supply is then inserted back next to the CDM-4001. If it is necessary to keep the supply powered whilst in place in the frame, it is possible to replace the front panel whilst the power supply is still within the frame. If a DC supply is being used instead of an AC supply, contact IRT Electronics for a replacement DC front panel instead of the standard supplied AC front panel.

Signal connections to this card are via the rear of the frame below the IEC mains plug input. The 9 pin female D9 connector is an RS-232 interface for connection to a computer for initial setup parameters of the frame for SNMP use. The RJ45 connector is for Ethernet connection.

### Front & rear panel connector diagrams

The following front panel and rear assembly drawings are not to scale and are intended to show relative positions of connectors, indicators and controls only.

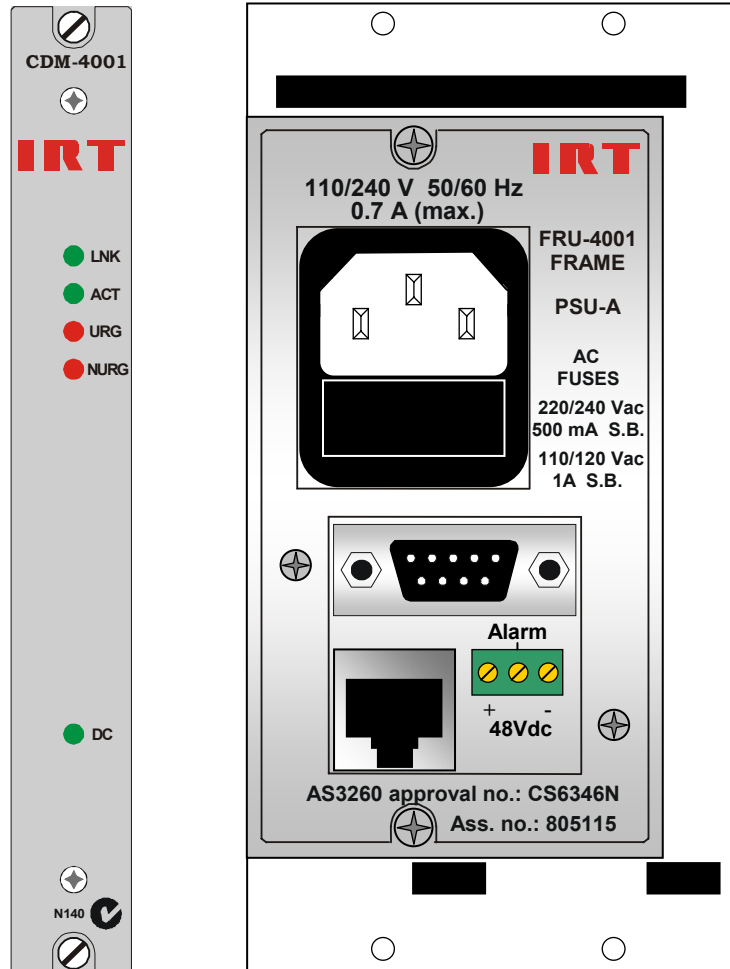

## CDM-4001 Setup

The communication between the CDM-4001 and the NMSs use Ethernet at either 10 or 100Mb/s.

The SNMP protocol used is Version 1. Read and Write functions use the same Community string.

To obtain a response from a CDM-4001 the Internet Protocol (IP) Destination address must be the preconfigured Local IP Address, the IP Source Address must be one of the pre-configured NMS addresses, the UDP Port number must match the preconfigured Agent Port, and the Community string must match the pre-configured Community string.

The Community string is also used to address individual modules. The frame slots are numbered from 1 to 9 then A to C (case sensitive) (giving 12 in all). To address a module the first character of the Community string must be the module Slot number in ASCII. The second character must be "@". The remaining characters must match the pre-configured Community string. For example suppose the Community was set as "public" then the module in Slot 1 would respond to "1@public" The CDM-4001 can also be addressed as being in slot '0' (i.e. "0@public" or "public").

To configure the CDM-4001 connect an ASCII serial RS-232 terminal (such as Tera Term PRO) to the Configuration port. The data rate should be 9600 baud and the byte should 8 bits data, no parity 1 stop. Upon sending 'Enter' you would typically see the following:

```
1.Local MAC address 12:34:56:78:9A:DF
2.Local IP address 192.168.0.100
3.NMS 1 IP Address 192.168.0.11    00:A0:CC:54:12:84
4.NMS 2 IP Address 255.255.255.255
5.NMS 3 IP Address 192.168.0.10    00:A0:CC:54:12:8E
6.NMS 4 IP Address 192.168.0.24    00:A0:CC:54:12:86
7.NMS 5 IP Address 192.168.0.9     00:09:5B:04:16:48
8.Gateway IP Address 192.168.0.1   00:09:5B:12:33:15
9. Subnet Mask      0.0.0.0
A.Community        public
B.Agent Port       161
C.Trap Port        162
D.sysContact       John Doe
E.sysLocation      Hotham Pde
F.sysName          north side
```

To change a parameter, type in the line number that you wish to change. As soon as the line number has been typed you are able to enter the new parameter data. Pressing the 'Enter' key will give you a message asking if you wish to replace the existing data with the new data. Press 'Enter' again to accept the change. Anything else typed will default back to the existing parameter.

### Local MAC address

This is a unique address of this particular CDM-4001 and should only be changed with great care.

### Local IP address

This is the static IP address assigned to the Frame by you or your ISP.

### NMS 1 IP Address

This is the IP address of one of the NMSs to which the CDM-4001 will respond. Up to 5 addresses can be used. If any one of the addresses is not required then the address 255.255.255.255 should be entered.

Once communication has been established with a particular address then the MAC address used to communicate with that IP address will be displayed after the IP address. If the IP address is not within the local subnet as defined by the Gateway address and the Subnet Mask then instead of the MAC address the label "via Gateway" will appear.

### Gateway IP Address

When using subnets a Gateway is the IP address of the computer appointed to pass on all messages that are addressed to computers that are not part of your subnet. **The Gateway IP address must be in your subnet.**

### Subnet Mask

A subnet mask is used to determine if an IP address is within your subnet or not. If the IP address is within your subnet then you send messages directly to that IP address. If it is not then you send messages to the Gateway for it to pass on.

Say the mask was 255.255.0.0 – and the destination IP address was 192.168.0.54 and the Gateway address was 192.168.0.1. Using binary logic you AND the IP address and the mask which results in 192.168.0.0 . Now AND the mask and the Gateway address and you get 192.168.0.0 . These two addresses match so the destination is in your local subnet.

If you do not want to use Gateways set the Mask to 0.0.0.0

### Community

This is the Community string, which must be exactly matched for a response to be obtained. It is case sensitive and you may use non-printable characters. The maximum length is 63.

### Agent Port

This is the Agents UDP Port number. SNMP Protocol suggests that this should be 161.

### Trap Port

When a Trap (an unsolicited message from a module to a NMS) is sent the Trap Port number is used as the destination port. SNMP Protocol suggests that this should be 162. Note that when a module generates a trap, it is sent to all of the configured NMS addresses using this Port number.

### sysContact

This string is sent when a 'Get sysContact' is sent to the CDM-4001. Maximum length is 63 and only printable characters should be used.

### sysLocation

This string is sent when a 'Get sysLocation' is sent to the CDM-4001. Maximum length is 63 and only printable characters should be used.

### sysName

This string is sent when a 'Get sysName' is sent to the CDM-4001. Maximum length is 63 and only printable characters should be used.

IRT-MIB.my is an SNMP MIB, which contains the Object Identifier (OID) definitions of all IRT controllable modules. It also contains a small number of OIDs used by modules that do not have their own MIB.

IRT4000FRU-MIB.my is an SNMP MIB specifically for the CDM/FRU-4001, as well as for the earlier CDM/FRU-4000 frame combination. A 'Walk' command to a CDM-4001 will show (in part) a list by slot number of the type of module installed.

If enabled, the CDM-4001 will issue a Trap on failure of either of the two possible PSU-4001 PSUs in the frame, as well as issuing Traps on each individual slot position. Trap alarms can be individually enabled or disabled for each slot position.

## **SNMP Plug-in Management Controller Type SMU-4000**

### **SMU-4000 General Description**

The SMU-4000 is a Simple Network Management Protocol (SNMP) plug-in interface option for IRT 4000 series modules when used in IRT's SNMP capable frames.

The SMU-4000 is programmed with a Management Information Base (MIB) suitable for the type of module that it is to be plugged into.

IRT 4000 series cards that are SNMP upgradeable need the SMU-4000 plug-in module programmed with their own relevant MIB to be recognisable by the SNMP system.

The SMU-4000 acts as an interface between the module that it is plugged into and the CDM-xxxx SNMP Agent within the SNMP capable frame. Module conditions such as alarm states or signal conditions are communicated to the SNMP Network Management System (NMS) via the CDM-xxxx SNMP Agent. Likewise control commands are communicated from the NMS, to the SNMP Agent, to the relevant module via the SMU-4000 plug-in module.

#### **Features:**

- **Plug-in SNMP option for IRT 4000 series cards**
- **Programmable Management Information Base (MIB) to suit intended module**

## SMU-4000 Installation

The SMU-4000 plug-in SNMP management controller module can only be fitted to IRT's 4000 series modules that are capable of being SNMP upgradeable. To determine whether a module is SNMP upgradeable, a square section on the main PCB is silk screened and fitted with three multipin sockets – as shown below:

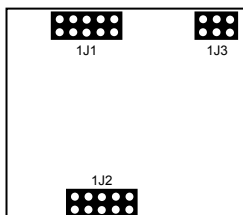

This is where the SMU-4000 plug-in SNMP management controller module is fitted. The three sets of multipins on the underside of the SMU-4000 line up with the three sets of multipin sockets on the main PCB module. Align all pins and then gently press the SMU-4000 all the way down into place.

If the SMU-4000 is not already programmed with the correct firmware to match the module that it is being plugged into, it then needs to be programmed via the pins on the topside of the SMU-4000.

Note that installation will generally be done by IRT Electronics at the time of ordering.

Note also that an SMU-4000 will only be functionally operational when the main module that it is plugged into is fitted into an IRT SNMP capable frame fitted with a CDM-xxxx SNMP agent and being interrogated by a suitable Network Management System.

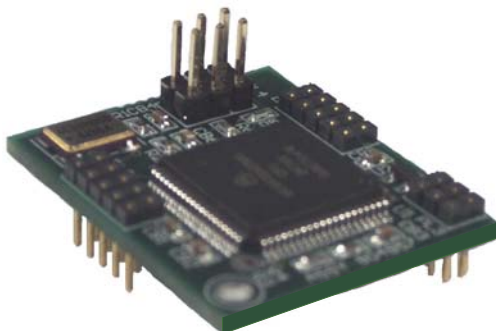

Figure 1: SMU-4000 module

## SNMP

### What Is It?

SNMP stands for Simple Network Management Protocol. It is an application layer protocol for managing IP (Internet Protocol) based systems. SNMP enables system administrators to manage system performance, and to find and solve system problems. SNMP runs over UDP (User Datagram Protocol), which in turn runs over IP.

Three types of SNMP exist: SNMP version 1 (SNMPv1), SNMP version 2 (SNMPv2) and SNMP version 3 (SNMPv3). It is not the intention here to discuss the differences between various versions, only to bring attention to the fact that IRT Electronics modules, fitted with SNMP capability, use SNMPv1.

An SNMP managed network consists of three key components: Network Management Systems (*NMS*), *agents*, and *managed devices*.

An *NMS* is the console through which the network administrator performs network management functions, such as monitoring status (e.g. alarm states) and remote controlling, of a set of managed devices. One or more *NMS*s must exist on any managed network. Generally the *NMS* is a computer running third party SNMP control software. There are a number of third party SNMP software applications currently available on the market.

An *NMS* polls, or communicates with, an *agent*. An *agent* is a network management software module that resides in a *managed device*. An *agent* has local knowledge of management information and translates that information into a form compatible with SNMP. The *agent*, therefore, acts as an interface between the *NMS* and the managed devices. The *NMS* sends a request message, and control commands for the managed devices, to the *agent*, which in turn sends a response message, containing information about the *managed devices*, back to the *NMS*.

A *managed device* contains an SNMP *agent* and resides on a managed network. *Managed devices* collect and store management information and make this information available to *NMS*s using SNMP.

*Managed device agent* variables are organised in a tree structure known as a Management Information Base (*MIB*). Within the *MIB* are parameters pertaining to the *managed device*. An Object Identifier (OID) number within the *MIB* defines the managed device type. This is a unique number specific to the model of *managed device*. Other information relating to the device is also stored, information such as alarm states, controllable settings, etc. The *MIB* tree is organised in such a way that there will be no two *MIB* files with conflicting placements.

Normally an *NMS* polls an *agent* for information relating to the *MIB* in a managed device to be sent back to the *NMS*. When certain conditions are met within the *MIB*, such as major alarm conditions, for example, the *agent* automatically sends what is known as a *trap* to the *NMS* without any prompting from the *NMS*. This allows automatic notification of a predetermined event.

**SNMP Block Diagram**

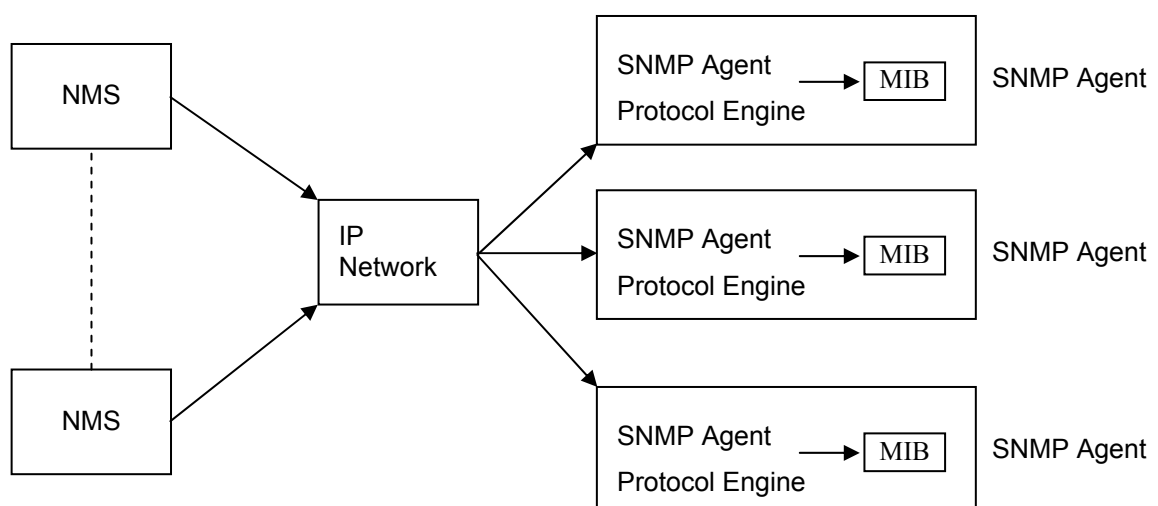

**SNMP with IRT Products:**

IRT Electronics currently employs SNMPv1 with its SNMP capable frames. The frame acts as an *agent* when fitted with a CDM-xxxx module. This module has its own designated slot next to the power supply so as to not affect the number of modules that the frame will take. Communication between the *NMS*, the frame and its loaded modules are via this CDM-xxxx module. Note that the *NMS* software is third party and not supplied by IRT Electronics.

Ethernet connection for SNMP operation is via an RJ45 connector on the rear of the frame, below the mains inlet. Ethernet rate runs at either 10 baseT or 100 baseT.

Frame parameters, such as Name, Address and Location, are set via an RS232 interface, a D9 connector on the rear of the frame below the mains inlet. A software terminal emulator, such as Tera Term or HyperTerminal, is used for setting and reading the parameters of the frame.

IRT modules that are SNMP compatible need a plug-in SMU-4000 module with a program relevant to the module that it is plugged into. Depending on the module, besides the module identification, parameters such as alarm states, inputs and controls etc. are communicated to the CDM-xxxx *agent* via a data bus on the rear of the frame. Thus the CDM-xxxx collects information on what is loaded within the frame, what positions they occupy, and their current status for communication to the *NMS* when the *NMS* sends a request for information.

In the event of a major alarm from any of the SNMP compatible modules, or power supplies, a *trap* is automatically sent by the CDM-xxxx *agent* to the *NMS* without any prompting by the *NMS*. This alerts the operator to any fault conditions that may exist that need immediate attention.

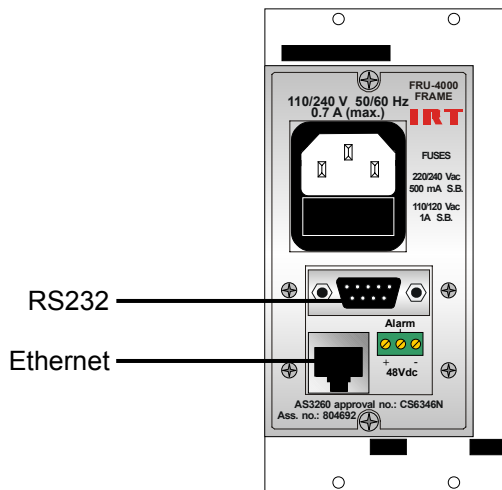

**IRT SNMP Connections**

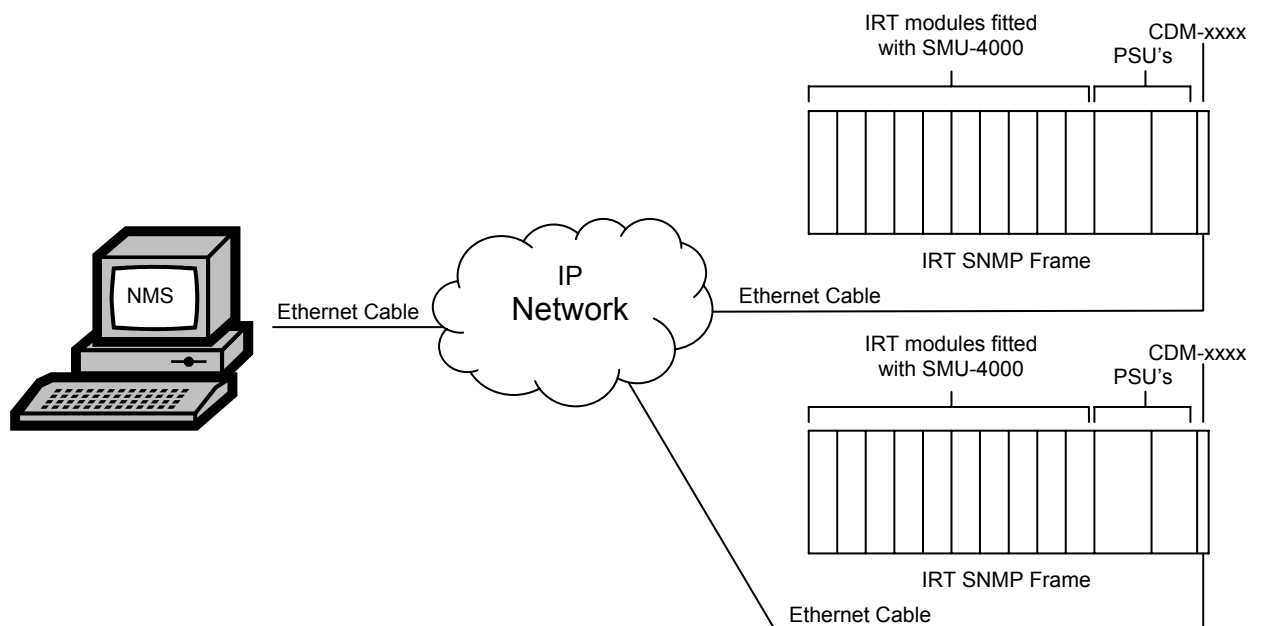

**IRT SNMP Setup**

## Maintenance & Storage

### Maintenance:

No regular maintenance is required.

Care however should be taken to ensure that all connectors are kept clean and free from contamination of any kind. This is especially important in fibre optic equipment where cleanliness of optical connections is critical to performance.

### Storage:

If the equipment is not to be used for an extended period, it is recommended the whole unit be placed in a sealed plastic bag to prevent dust contamination. In areas of high humidity a suitably sized bag of silica gel should be included to deter corrosion.

Where individual circuit cards are stored, they should be placed in antistatic bags. Proper antistatic procedures should be followed when inserting or removing cards from these bags.

## Warranty & Service

Equipment is covered by a limited warranty period of three years from date of first delivery unless contrary conditions apply under a particular contract of supply. For situations when “No **Fault Found**” for repairs, a minimum charge of 1 hour’s labour, at IRT’s current labour charge rate, will apply, whether the equipment is within the warranty period or not.

Equipment warranty is limited to faults attributable to defects in original design or manufacture. Warranty on components shall be extended by IRT only to the extent obtainable from the component supplier.

### Equipment return:

Before arranging service, ensure that the fault is in the unit to be serviced and not in associated equipment. If possible, confirm this by substitution.

Before returning equipment contact should be made with IRT or your local agent to determine whether the equipment can be serviced in the field or should be returned for repair.

The equipment should be properly packed for return observing antistatic procedures.

The following information should accompany the unit to be returned:

1. A fault report should be included indicating the nature of the fault
2. The operating conditions under which the fault initially occurred.
3. Any additional information, which may be of assistance in fault location and remedy.
4. A contact name and telephone and fax numbers.
5. Details of payment method for items not covered by warranty.
6. Full return address.
7. For situations when “No **Fault Found**” for repairs, a minimum charge of 1 hour’s labour will apply, whether the equipment is within the warranty period or not. Contact IRT for current hourly rate.

Please note that all freight charges are the responsibility of the customer.

The equipment should be returned **to the agent who originally supplied the equipment** or, where this is not possible, to IRT direct as follows.

Equipment Service  
IRT Electronics Pty Ltd  
26 Hotham Parade  
ARTARMON  
N.S.W. 2064  
AUSTRALIA

Phone: 61 2 9439 3744

Fax: 61 2 9439 7439

Email: [service@irtelectronics.com](mailto:service@irtelectronics.com)