



IRT Electronics Pty Ltd A.B.N. 35 000 832 575
26 Hotham Parade, ARTARMON N.S.W. 2064 AUSTRALIA
National: Phone: (02) 9439 3744 Fax: (02) 9439 7439
International: +61 2 9439 3744 +61 2 9439 7439
Email: sales@irtelectronics.com
Web: www.irtelectronics.com

IRT Eurocard
Type DVC-4112
270 Mb/s Serial Digital VDA
with
Reclocked & Composite Outputs

Designed and manufactured in Australia

IRT can be found on the Internet at:
<http://www.irtelectronics.com>

IRT Eurocard
Type DVC-4112
270 Mb/s Serial Digital VDA
with
Reclocked & Composite Outputs
Instruction Book

Table of Contents

| Section | Page |
|---------------------------------------|------|
| Operational Safety | 2 |
| General Description | 3 |
| Technical Specifications | 4 |
| Configuration | 5 |
| Link Settings | 5 |
| SNMP | 6 |
| DVC-4112 SNMP Functions | 8 |
| Installation | 9 |
| Front & rear panel connector diagrams | 10 |
| Maintenance & storage | 11 |
| Equipment return | 11 |

This instruction book applies to units later than S/N 0601001.

Operational Safety:

WARNING

Operation of electronic equipment involves the use of voltages and currents that may be dangerous to human life. Note that under certain conditions dangerous potentials may exist in some circuits when power controls are in the **OFF** position.

Maintenance personnel should observe all safety regulations.

Do not make any adjustments inside equipment with power **ON** unless proper precautions are observed. All internal adjustments should only be made by suitably qualified personnel. All operational adjustments are available externally without the need for removing covers or use of extender cards.

**IRT Eurocard
Type DVC-4112
270 Mb/s Serial Digital VDA
with
Reclocked & Composite Outputs**

General Description

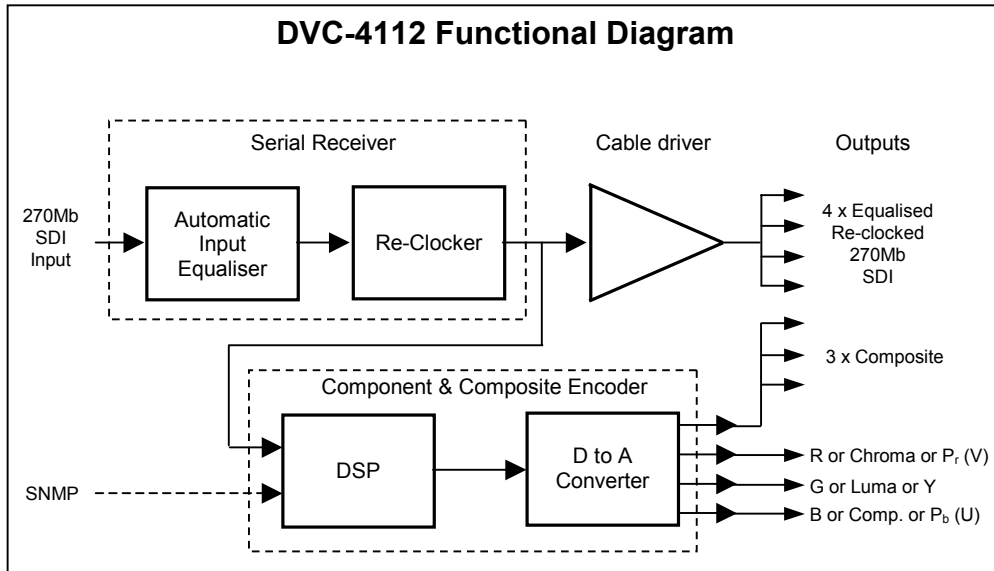

The DVC-4112 is a high performance SDI 270 Mbit/s serial digital video to analogue composite/component converter and distribution amplifier.

The DVC-4112 is designed to regenerate a link and provide a broadcast quality analogue composite or component signal.

The serial receiver section, shown in the block diagram above, automatically equalises and re-clocks the input serial video signal and the cable driver section retransmits the regenerated serial video.

This configuration allows both an extension of the link and a jitter performance advantage over non re-clocking regenerators.

The DVC-4112 is primarily intended to operate in mixed (digital and analogue) environments allowing existing analogue monitoring equipment to be utilised without the need to purchase more expensive digital equipment.

The DVC-4112 provides component outputs for most requirements: RGB, YP_bP_r and S-VHS (Luma + Chroma). Three composite outputs are always available plus a choice of one of the remaining component formats.

Full 10 bit video processing and 10-bit digital to analogue converters are used in order to assure a high quality analogue signal suitable for broadcast and production monitoring applications.

Simple Network Management Protocol (SNMP) monitoring is possible if mounted in IRT's 4000 series frame fitted with SNMP capability.

Features:

- **Broadcast quality, full 10-bit video conversion.**
- **4 Equalised, regenerated and re-clocked repeater outputs.**
- **3 Composite analogue outputs with high quality 10 bit D to A.**
- **Component (RGB, YP_bP_r) or S-Video (Y/C) output.**
- **PAL or NTSC operation with auto or manual switching.**
- **SDI input loss and decoded video indicators on front panel.**
- **Simple Network Management Protocol (SNMP) capability.**

Technical Specifications

IRT Eurocard Module DVC-4112

Input:

| | |
|--------------|--|
| Connector | BNC. |
| Format | 270 Mbit/s SDI (Serial CCIR601, 4:2:2). |
| Impedance | 75Ω |
| Equalisation | Automatic, better than 200 metres at 270 Mb/s for Belden 8281 or equivalent cable. |

Outputs - Digital:

| | |
|--------------|--|
| Number | 4. |
| Connectors | BNC. |
| Format | Re-clocked 270 Mbit/s SDI (Serial CCIR601, 4:2:2). |
| Signal Level | 800 mV ±10%. |

Outputs - Analogue:

| | |
|------------|---|
| Number | 3 x composite plus 1 x RGB / YP _b P _r / YC component. |
| Connectors | BNC. |

Performance:

| | |
|--------------------------------------|----------------------------------|
| Differential gain | <0.5 % |
| Differential phase | <0.5° |
| Luminance non linearity | <1% p-p. |
| 2T pulse K factor | K-2T <0.5% KF |
| Noise level (10 KHz - 5 MHz unified) | <-80 dBrms |
| Hsync jitter in a frame | <3 ns p-p |
| Frame period jitter | <5 ns p-p |
| Power requirements | 28 Vac CT (14-0-14) or ± 16 Vdc. |
| Power consumption | <240 mA. |

Other:

| | |
|----------------------|---|
| Temperature range | 0 - 50° C ambient |
| Mechanical | Suitable for mounting in IRT 19" rack chassis with input output and power connections on the rear panel |
| Finish: Front panel | Grey background, silk-screened black lettering & red IRT logo |
| Rear assembly | Detachable silk-screened PCB with direct mount connectors to Eurocard and external signals |
| Dimensions | 32 mm x 3 U x 220 mm IRT Eurocard |
| Standard accessories | Rear connector assembly. |
| Links | Component output selection (LK3 & LK4) RGB sync insertion (LK5) NTSC Pedestal insertion (LK6) Digital Noise Reduction (LK7) Digital Noise Shaping (LK8) Pass Vertical Blanking Information (LK9) |

Due to our policy of continuing development, these specifications are subject to change without notice.

Configuration

Front Panel Controls & Indicators:

NTSC - AUTO -PAL select

270 Mbit PAL
270 Mbit NTSC
Loss of input video
Power on

Component or composite auxiliary outputs: - (default 3 x composite plus 1 x RGB)

The DVC-4112 has three dedicated composite outputs. In addition, three analogue outputs are available which are assignable as Y & C (S-Video) and one extra composite or as RGB or YP_bP_r.

The Y & C outputs allow monitors with S-Video inputs or SVHS recorders to be used to best advantage.

| SW1 | PAL, NTSC or Auto configuration |
|--------|---------------------------------|
| Up | NTSC |
| Centre | Auto (detect) |
| Down | PAL |

Link Settings:

| Component Output | Link Settings | |
|--------------------------------|---------------|-----|
| | LK3 | LK4 |
| RGB | OUT | OUT |
| YP _b P _r | OUT | IN |
| YC (+ Composite) | IN | X |

Output connector assignments:

| | | | |
|------|-----|-------|------------------|
| LK 3 | OUT | SK 10 | R |
| LK 4 | OUT | SK 11 | G |
| | | SK 9 | B |
| LK 3 | OUT | SK 10 | P _r |
| LK 4 | IN | SK 11 | Y |
| | | SK 9 | P _b |
| LK 3 | IN | SK 10 | Chroma (C) |
| | | SK 11 | Luminance (Y) |
| | | SK 9 | Composite (Comp) |

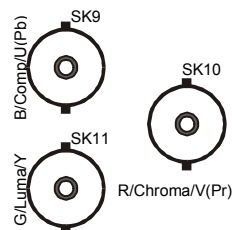

RGB / YP_bP_r Sync

| | | |
|------|-----|--|
| LK 5 | OUT | Sync added to ALL component outputs (RGB or YP _b P _r) |
| LK 5 | IN | No sync on ANY component outputs (RGB or YP _b P _r) |

NTSC Pedestal

If NTSC format is selected

| | | |
|------|-----|-------------|
| LK 6 | IN | no pedestal |
| LK 6 | OUT | pedestal |

Digital Noise Reduction

| | | |
|------|-----|-----------------------------------|
| LK 7 | IN | Digital Noise Reduction (DNR) ON |
| LK 7 | OUT | Digital Noise Reduction (DNR) OFF |

Digital Noise Shaping

| | | |
|------|-----|---------------------------------|
| LK 8 | IN | Digital Noise Shaping (DNS) ON |
| LK 8 | OUT | Digital Noise Shaping (DNS) OFF |

Vertical Blanking Interval

| | | |
|------|-----|--|
| LK 9 | IN | Pass Vertical Blanking Interval (VBI) |
| LK 9 | OUT | Blank Vertical Blanking Interval (VBI) |

SNMP

What Is It?

SNMP stands for Simple Network Management Protocol. It is an application layer protocol for managing IP (Internet Protocol) based systems. SNMP enables system administrators to manage system performance, and to find and solve system problems. SNMP runs over UDP (User Datagram Protocol), which in turn runs over IP.

Three types of SNMP exist: SNMP version 1 (SNMPv1), SNMP version 2 (SNMPv2) and SNMP version 3 (SNMPv3). It is not the intention here to discuss the differences between various versions, only to bring attention to the fact that IRT Electronics modules, fitted with SNMP capability, use SNMPv1.

An SNMP managed network consists of three key components: Network Management Systems (*NMS*), *agents*, and *managed devices*.

An *NMS* is the console through which the network administrator performs network management functions, such as monitoring status (e.g. alarm states) and remote controlling, of a set of managed devices. One or more *NMS*s must exist on any managed network. Generally the *NMS* is a computer running third party SNMP control software. There are a number of third party SNMP software applications currently available on the market.

An *NMS* polls, or communicates with, an *agent*. An *agent* is a network management software module that resides in a *managed device*. An *agent* has local knowledge of management information and translates that information into a form compatible with SNMP. The *agent*, therefore, acts as an interface between the *NMS* and the managed devices. The *NMS* sends a request message, and control commands for the managed devices, to the *agent*, which in turn sends a response message, containing information about the *managed devices*, back to the *NMS*.

A *managed device* contains an SNMP *agent* and resides on a managed network. *Managed devices* collect and store management information and make this information available to *NMS*s using SNMP.

Managed device agent variables are organised in a tree structure known as a Management Information Base (*MIB*). Within the *MIB* are parameters pertaining to the *managed device*. An Object Identifier (OID) number within the *MIB* defines the managed device type. This is a unique number specific to the model of *managed device*. Other information relating to the device is also stored, information such as alarm states, controllable settings, etc. The *MIB* tree is organised in such a way that there will be no two *MIB* files with conflicting placements.

Normally an *NMS* polls an *agent* for information relating to the *MIB* in a managed device to be sent back to the *NMS*. When certain conditions are met within the *MIB*, such as major alarm conditions, for example, the *agent* automatically sends what is known as a *trap* to the *NMS* without any prompting from the *NMS*. This allows automatic notification of a predetermined event.

SNMP Block Diagram

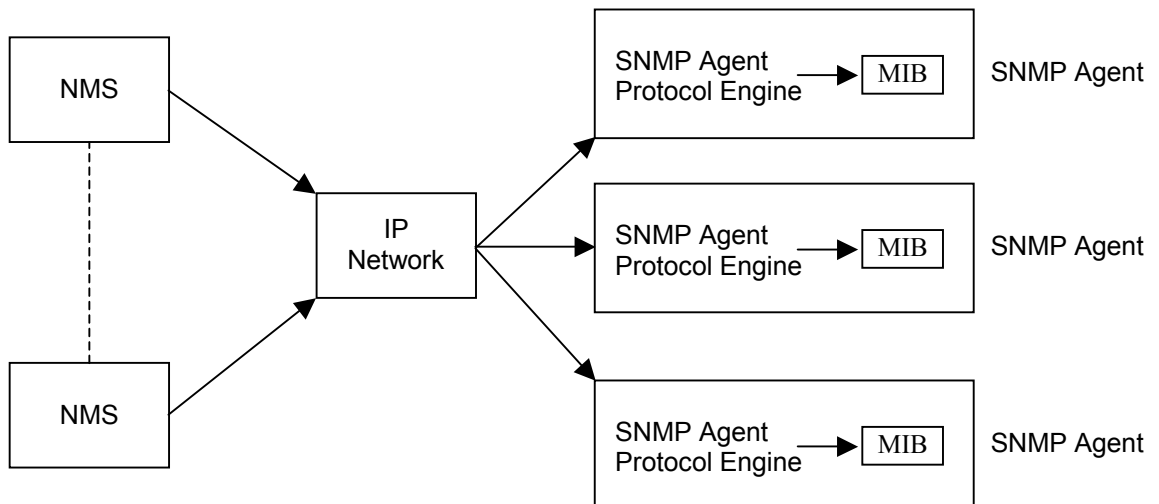

SNMP with IRT Products

IRT Electronics currently employs SNMPv1 with its 4000 series frame. The frame acts as an *agent* when fitted with a CDM-4000 module. This module has its own designated slot next to the power supply so as to not affect the number of modules that the frame will take. Communication between the *NMS*, the frame and its loaded modules are via this CDM-4000 module. Note that the *NMS* software is third party and not supplied by IRT Electronics.

Ethernet connection for SNMP operation is via an RJ45 connector on the rear of the frame, below the mains inlet. Ethernet rate runs at either 10 baseT or 100 baseT.

Frame parameters, such as Name, Address and Location, are set via an RS232 interface, a D9 connector on the rear of the frame below the mains inlet. A software terminal emulator, such as Tera Term or HyperTerminal, is used for setting and reading the parameters of the frame.

IRT modules that are SNMP compatible need a plug-in SMU-4000 module with a program relevant to the module that it is plugged into. Depending on the module, besides the module identification, parameters such as alarm states, inputs and controls etc. are communicated to the CDM-4000 *agent* via a data bus on the rear of the frame. Thus the CDM-4000 collects information on what is loaded within the frame, what positions they occupy, and their current status for communication to the *NMS* when the *NMS* sends a request for information.

In the event of a major alarm from any of the SNMP compatible modules, or power supplies, a *trap* is automatically sent by the CDM-4000 *agent* to the *NMS* without any prompting by the *NMS*. This alerts the operator to any fault conditions that may exist that need immediate attention.

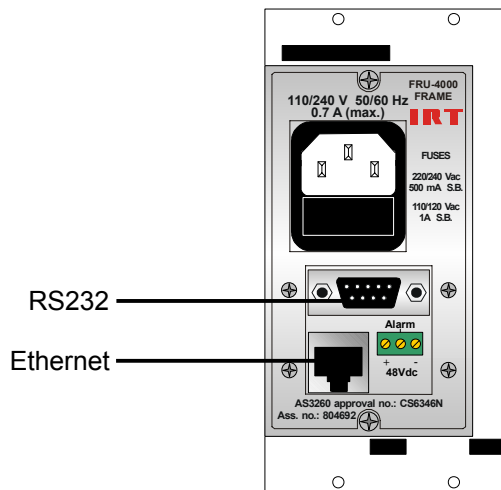

IRT SNMP Connections

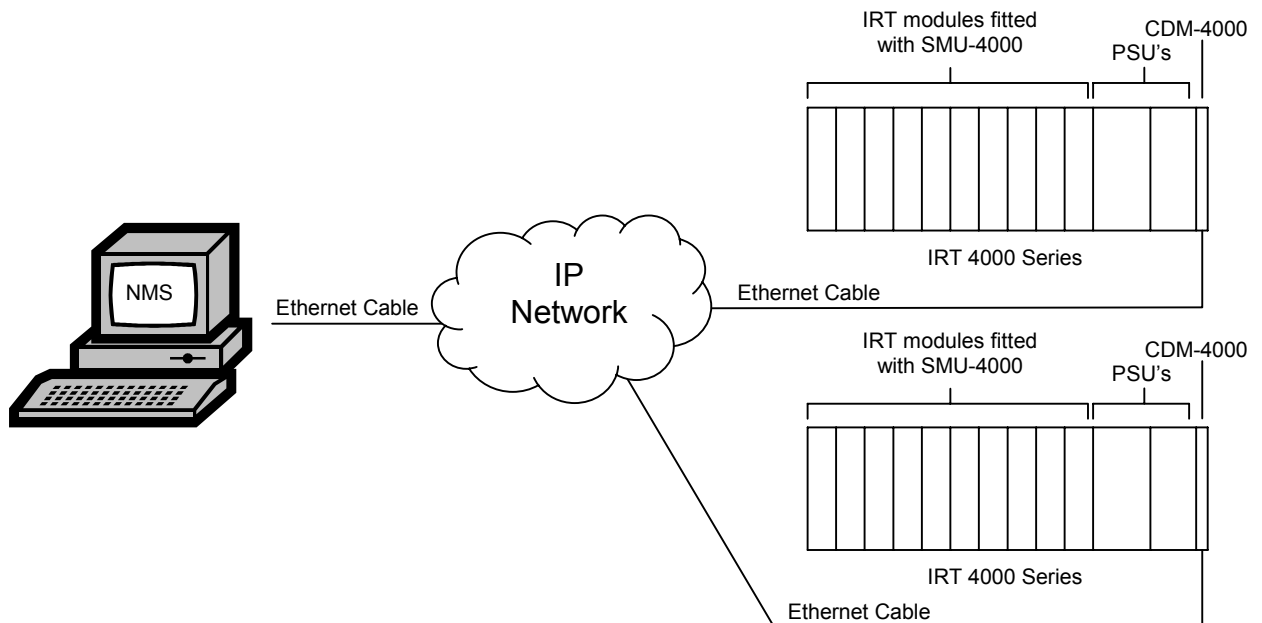

IRT 4000 Series SNMP Setup

DVC-4112 SNMP Functions:

With the DVC-4112 installed in an IRT 4000 series frame with SNMP capability, the DVC-4112 can be interrogated by an SNMP Network Management System (NMS).

The following SNMP functions are capable of being monitored by an NMS:

- An indication that the video input is present and whether it is PAL or NTSC;
- An indication of the output video format, whether it be YC, YP_bP_r, or RGB;
- An indication, if the output is RGB, if sync is added to each output;
- An indication, if the video system is NTSC, if the NTSC Pedestal is on or off;
- An indication whether vertical interval will be passed or blanked;
- Whether “Trap” function is enabled;
- Trap automatically sent, if enabled, if the input signal fails;
- Unit reset control.

Installation

Pre-installation:

Handling:

This equipment may contain or be connected to static sensitive devices and proper static free handling precautions should be observed.

Where individual circuit cards are stored, they should be placed in antistatic bags. Proper antistatic procedures should be followed when inserting or removing cards from these bags.

Power:

AC mains supply: Ensure that operating voltage of unit and local supply voltage match and that correct rating fuse is installed for local supply.

DC supply: Ensure that the correct polarity is observed and that DC supply voltage is maintained within the operating range specified.

Earthing:

The earth path is dependent on the type of frame selected. In every case particular care should be taken to ensure that the frame is connected to earth for safety reasons. See frame manual for details.

Signal earth: For safety reasons a connection is made between signal earth and chassis earth. No attempt should be made to break this connection.

Installation in frame or chassis:

See details in separate manual for selected frame type.

Digital Video Connections:

SDI Input and outputs are 75 Ω BNC type for connection with high quality 75 Ω coaxial cable. Input is self-terminating. No loop through facility is available.

Analogue Output Video Connections:

The DVC-4112 comes setup for 3 composite outputs and one RGB component output as standard, all of which are 75 Ω BNC type for connection with high quality 75 Ω coaxial cable.

Links LK3 and LK4 change the RGB output to either YP_bP_r or YC + an extra composite. See *Configuration* section for link set-ups.

Alarm Output Connection:

A 2 pin phoenix style screw connector is provide on the rear assembly for an alarm connection for loss of SDI input or loss of power. The output of this is either a switch to ground or switch from ground, depending on the position of link LK11 being in the normally closed (n.c.) or normally open (n.o.) position, respectively.

Front & rear panel connector diagrams

The following front panel and rear assembly drawings are not to scale and are intended to show relative positions of connectors, indicators and controls only.

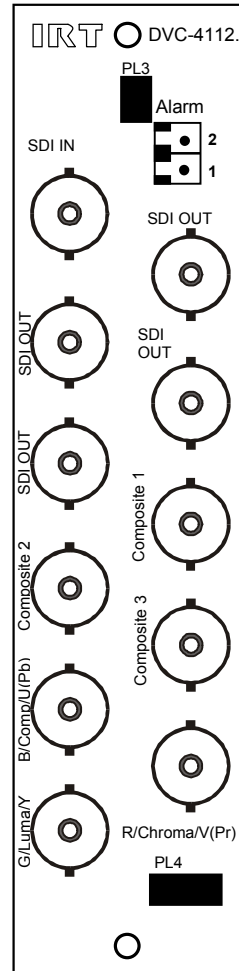
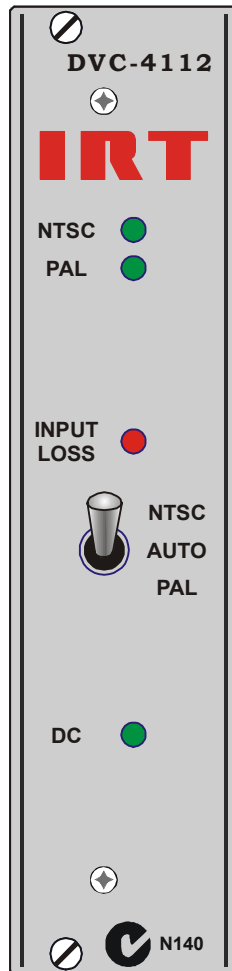

Maintenance & storage

Maintenance:

No regular maintenance is required.

Care however should be taken to ensure that all connectors are kept clean and free from contamination of any kind. This is especially important in fibre optic equipment where cleanliness of optical connections is critical to performance.

Storage:

If the equipment is not to be used for an extended period, it is recommended the whole unit be placed in a sealed plastic bag to prevent dust contamination. In areas of high humidity a suitably sized bag of silica gel should be included to deter corrosion.

Where individual circuit cards are stored, they should be placed in antistatic bags. Proper antistatic procedures should be followed when inserting or removing cards from these bags.

Warranty & service

Equipment is covered by a limited warranty period of three years from date of first delivery unless contrary conditions apply under a particular contract of supply. For situations when “**No Fault Found**” for repairs, a minimum charge of 1 hour’s labour, at IRT’s current labour charge rate, will apply, whether the equipment is within the warranty period or not.

Equipment warranty is limited to faults attributable to defects in original design or manufacture. Warranty on components shall be extended by IRT only to the extent obtainable from the component supplier.

Equipment return:

Before arranging service, ensure that the fault is in the unit to be serviced and not in associated equipment. If possible, confirm this by substitution.

Before returning equipment contact should be made with IRT or your local agent to determine whether the equipment can be serviced in the field or should be returned for repair.

The equipment should be properly packed for return observing antistatic procedures.

The following information should accompany the unit to be returned:

1. A fault report should be included indicating the nature of the fault
2. The operating conditions under which the fault initially occurred.
3. Any additional information, which may be of assistance in fault location and remedy.
4. A contact name and telephone and fax numbers.
5. Details of payment method for items not covered by warranty.
6. Full return address.
7. For situations when “**No Fault Found**” for repairs, a minimum charge of 1 hour’s labour will apply, whether the equipment is within the warranty period or not. Contact IRT for current hourly rate.

Please note that all freight charges are the responsibility of the customer.

The equipment should be returned **to the agent who originally supplied the equipment or, where this is not possible**, to IRT direct as follows.

Equipment Service
IRT Electronics Pty Ltd
26 Hotham Parade
ARTARMON
N.S.W. 2064
AUSTRALIA

Phone: 61 2 9439 3744 Fax: 61 2 9439 7439
Email: service@irtelectronics.com