



IRT Electronics Pty Ltd A.B.N. 35 000 832 575  
26 Hotham Parade, ARTARMON N.S.W. 2064 AUSTRALIA  
National: Phone: (02) 9439 3744 Fax: (02) 9439 7439  
International: +61 2 9439 3744 +61 2 9439 7439  
Email: sales@irtelectronics.com  
Web: www.irtelectronics.com

## IRT Eurocard

### Type HDT-4611 & HDR-4611

### 1.485 Gb/s HD & 270 Mb/s ASI / SDI Fibre Optic Link

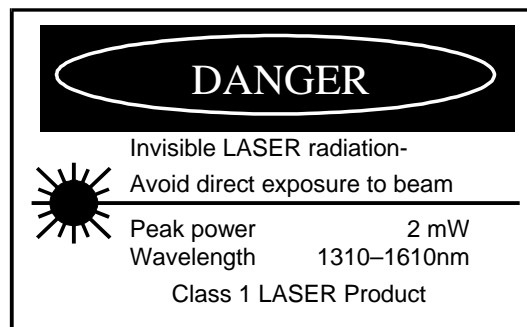

**Designed and manufactured in Australia**

IRT can be found on the Internet at:  
<http://www.irtelectronics.com>

# HDT-4611 & HDR-4611

## 1.485 Gb/s HD & 270 Mb/s ASI / SDI Fibre Optic Link

### Instruction Manual

#### Table of Contents

Item	Page
Operational Safety	3
General Description	4
Technical Specifications	5
Configuration	6
Operation	7
SNMP – What Is It?	8
HDT-4611 & HDR-4611 SNMP Functions	10
Installation	11
Front and rear layouts	12
Warranty & Service	13
Equipment return	13
Drawing index	14

This instruction book applies to units later than S/N 0804001.

## Operational Safety:

### WARNING

Operation of electronic equipment involves the use of voltages and currents that may be dangerous to human life. Note that under certain conditions dangerous potentials may exist in some circuits when power controls are in the **OFF** position. Maintenance personnel should observe all safety regulations.

Do not make any adjustments inside equipment with power **ON** unless proper precautions are observed. All internal adjustments should only be made by suitably qualified personnel. All operational adjustments are available externally without the need for removing covers or use of extender cards.

### Optical Safety

The light emitted from the LASER diode used in this system is invisible and may be harmful to the human eye. Avoid looking directly into the fibre optic cable or connectors or into the collimated beam along their axis when the device is in operation. Operating the LASER diode outside of its maximum ratings may cause device failure or a safety hazard.

**DANGER**

Invisible LASER radiation-  
Avoid direct exposure to beam

---

Peak power	2 mW
Wavelength	1310–1610nm

Class 1 LASER Product

**IRT Eurocard**  
**Type HDT-4611 & HDR-4611**  
**1.485 Gb/s HD & 270 Mb/s ASI / SDI Fibre Optic Link**

**General Description**

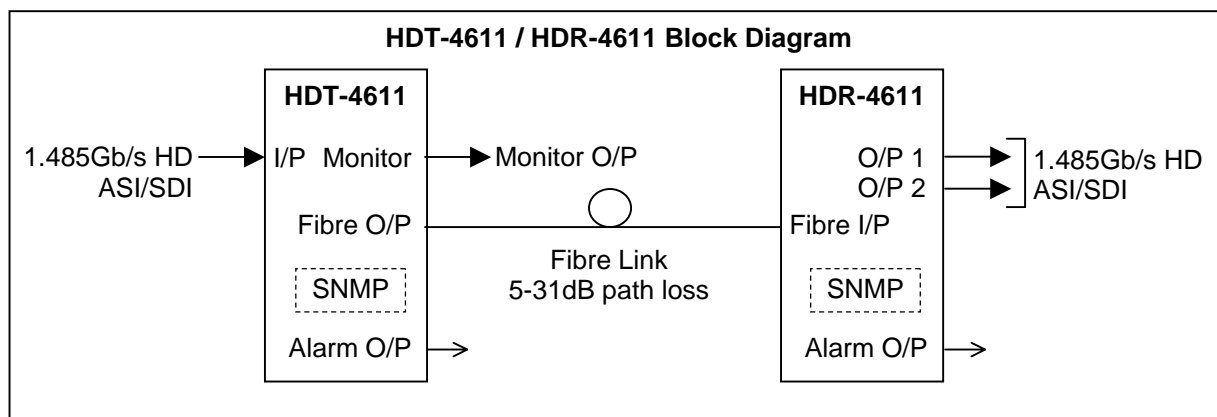

The IRT HDT-4611 and HDR-4611 are transmit and receive modules designed principally for use as a SMPTE292M 1.485 Gb/s serial digital video Fibre Optic transmission link, using 9/125 single mode fibre for path lengths with path attenuation of 5-31 dB. This enables the use of space saving fibre optic cable for reliable transmission of digital video signals over lengths greater than can be provided with coaxial cable. The transmit / receive system specifications apply to all signal conditions, including the SMPTE 292M pathological test sequence.

The HDT-4611 transmitter features an input circuit with automatic cable equalisation for Belden 8281 (or equivalent) coaxial cable followed by a plug-in LASER transmitter. A monitor output is provided on the rear assembly.

The HDR-4611 receiver uses a plug-in APD detector preamplifier module, signal conditioning and a reclocking circuit for the 1.485 Gb/s data rate, or for 270 Mb/s SDI and ASI signals. Two in phase serial digital outputs are provided from the transmission link on the rear assembly.

On the HDT-4611 transmitter LED indicators on the front panel indicate the presence of signal, loss of laser power and presence of DC power. Relay contact outputs for remote indication will indicate failure of the laser operation, loss of input signal, and loss of power.

On the HDR-4611 receiver LED indicators on the front panel indicate PLL lock at 1.485Gb/s or 270 Mb/s operation, locked signal presence, optical input failure, and presence of DC power. Relay contact outputs for remote indication will indicate loss of signal, loss of optical input, and loss of power.

An optional SNMP (Simple Network Management Protocol) plug-in module is available, for each unit, for remote monitoring when used in conjunction with IRT's 4000 series frame fitted with SNMP capability.

The HDT-4611 and HDR-4611 are Eurocard modules designed to fit IRT's standard range of Eurocard frames<sup>1</sup> and may be used alongside any other of IRT's analogue or digital Eurocards.

**Standard features:**

- One type covers 1.485 Gb/s High Definition or 270 Mb/s data signals.
- Work reliably over 5 - 31dB optical path range using 9/125µm single mode fibre.
- Passes SMPTE 292M pathological test sequence at 1.485 Gb/s and 270 Mb/s data.
- LED indicators and external alarm contacts.
- Fibre, video and alarm connections at rear.
- Optional plug-in SNMP monitoring module

**Applications:**

- Transmission of 1.485 Gb/s signals over distances > 100 meters.
- Eliminates ground loop problems.

<sup>1</sup> NOTE: For use with 1.485 Gb/s HD signals it is recommended that these modules be housed within an IRT 1RU or 4000 series 3RU frame only.

# Technical Specifications

## HDT-4611 - Transmitter

Input impedance	75 $\Omega$ .
Input return loss	>15 dB 5 MHz to 1.5 GHz,
Input serial data signal	SMPTE/EBU 1.485 Gb/s or 270 Mb/s serial data (SDI or ASI).
Input circuit cable compensation	Automatic, up to 100 metres at 1.485 Gb/s , and up to 250 metres at 270 Mb/s, for Belden 8281 or equivalent cable.
Input Connector	1, BNC on rear assembly.
Monitor Connector	1, BNC on rear assembly.

## HDR-4611 - Receiver

Number of outputs	2 data relocked, AC coupled.
Output level	800 mV $\pm$ 5% into 75 $\Omega$ .
Output impedance	75 $\Omega$ .
Output return loss	>15 dB 5 MHz to 1.5 GHz.
Output rise/fall time	<200 ps at 1.485 Gb/s, <600 ms at 270 Mb/s.
Residual Jitter	<0.2 UI at 1.485 Gb/s relocked, <0.1 UI at 270 Mb/s relocked.
Output Connector	2, BNC on rear assembly.

## Optical

Optical path loss*	5 - 31 dB.
Optical fibre	Designed for use with 9/125 single mode fibre.
Optical wavelength (standard)	1310 nm $\pm$ 30 nm.
Spectral width	3 nm typically.
Optical connectors	SC/PC on bracket attached to module.
HDT-4611 optical output	0 dBm +0, -1 dB.
HDR-4611 optical input*	-31 dBm min, -5 dBm max.

## Alarm/Control connections

Alarm outputs	Phoenix 4 pin terminal plug in block. Three relays energised in the normal condition to indicate loss of DC power, signal or laser power on the HDT-4611, or optical input low on the HDR-4611. Relay circuits are wired with contacts normally closed (or open) as set by a link on the circuit board.
---------------	--

## Power requirement:

Voltage	28 Vac CT (14-0-14 Vac) or $\pm$ 16 Vdc.
Consumption	HDT-4611 2.6 VA (90 mA), HDR-4611 3.7 VA (130 mA).

## General:

Operating temperature	0 to 50 $^{\circ}$ C ambient.	
Mechanical	Suitable for mounting in IRT 19" rack chassis with input, output and power connections to the rear. For use with 1.485 Gb/s HD signals it is recommended that these modules be housed within an IRT 1RU or 4000 series 3RU frame only.	
Size	6 HP x 3 RU Extended Eurocard (220 mm x 100 mm).	
Weight	HDT-4611: 405g, HDR-4611: 410g (with rear assembly)	
Finish	Front panel Rear assembly	Grey background, silk screened black lettering & red IRT logo. Detachable PCB with connectors to Eurocard and external signals.
Standard accessories	Rear connector panel (supplied with module).	
Optional accessories	SMU-4000 SNMP plug in module for use with 4000 series frame fitted with SNMP "Agent".	

NOTE:	*	5 or 10dB optical attenuator must be used for HDR-4611 when optical path loss is less than 5dB.
-------	---	---

**Due to our policy of continuing development these specifications are subject to change without notice.**

## Configuration

Other than the following link settings, there are no user configurable settings. All other potentiometer and link settings are factory set and should not be moved.

### User link settings:

#### HDT-4611:

- |      |     |  |
|------|-----|--|
| LK1  | 1-2 | Signal Loss alarm relay switched to ground on loss of input signal. (Default position).  |
|      | 2-3 | Signal Loss alarm relay switched to ground with input signal present.  |
| LK2  | 1-2 | Laser Fail/Off alarm relay switched to ground when laser is ok and on.   |
|      | 2-3 | Laser Fail/Off alarm relay switched to ground when laser fails or is switched off. (Default position).                             |
| LK3  | 1-2 | Power Fail alarm relay switched to ground when +5Vdc power rail fails. (Default position).   |
|      | 2-3 | Power Fail alarm relay switched to ground when +5Vdc power rail ok.  |
| LK4  | 1-2 | Enable Laser - laser is always enabled whether input signal is present or not. (Default position).                                 |
|      | 2-3 | Auto Laser – laser is enabled only when an input signal is present.  |
| LK5  | 1-2 | HD slew rate – adjust Output Monitor.slew rate to be optimised for HD.   |
|      | 2-3 | SD slew rate – adjust Output Monitor.slew rate to be optimised for SD.   |
| LK6* | IN  | Reduces the input equalisation sensitivity for 270MB SD signals for use in noisy environments or when a short input cable is used. |
|      | OUT | Input equalisation for 270Mb SD signals at maximum sensitivity.  |

#### HDR-4611:

- |     |     |  |
|-----|-----|--|
| LK1 | 1-2 | Signal Loss alarm relay switched to ground on loss of input signal. (Default position).  |
|     | 2-3 | Signal Loss alarm relay switched to ground with input signal present.  |
| LK2 | 1-2 | Optical Input Low alarm relay switched to ground when optical input is ok.   |
|     | 2-3 | Optical Input Low alarm relay switched to ground when getting close to, or exceeding, maximum optical path loss. Set to come on at approximately -28dBm optical input power. (Default position). |
| LK3 | 1-2 | Power Fail alarm relay switched to ground when +5Vdc power rail fails. (Default position).   |
|     | 2-3 | Power Fail alarm relay switched to ground when +5Vdc power rail ok.  |

Note: \* - Not Fitted.

## Operation

The HDT-4611 and HDR-4611 are set up to operate at either **1.485 Gb/s HD** or **270 Mb/s SD** and do not require any adjustment prior to use. There are no external controls on the front panel of the units.

A 1.485 Gb/s HD signal or a 270 Mb/s type of signal, such as ASI or SDI, is connected to a 75  $\Omega$  BNC connector on the rear assembly of the HDT-4611 fibre optic transmitter. A front panel LED, and a relay alarm accessible by the rear assembly, indicates the presence of a valid input signal. Likewise, front panel LEDs, and a relay alarm also accessible by the rear assembly, indicates when the laser module is ON or either fails or is automatically turned off on loss of input signal. Link settings set whether the laser is permanently enabled or only enabled whilst a valid input signal is present.

If the laser is set for permanent operation, on loss of an input signal, a 54MHz oscillator is switched into the optical output so that the HDR-4611 still recognizes the optical link as being valid. This 54MHz signal does not affect the signal reclocking detect circuitry of the HDR-4611, which is used in signal presence/alarm indication on detection or absence of a valid HD or SD signal.

A monitor output is available via a 75  $\Omega$  BNC connector on the rear assembly. Link LK5 sets the slew rate for either SD or HD on the monitor output. This slew rate setting does not affect the signal transmitted via the fibre output.

With an optical laser sub-board fitted to the transmitter, single mode optical cable is directly connected to the module at the rear of the unit. Likewise the fibre connection at the far end of the fibre optic cable is directly connected to the rear of the receiver.

The system will operate with an optical path loss from 5dB to a maximum of 31dB. For path lengths <5dB optical loss, an optical attenuator is recommended. The length of fibre that this corresponds to depends on the fibre loss characteristics at the relevant wavelength of the laser module chosen. For example, if the fibre loss characteristic of the chosen fibre is 0.3dB per kilometre at 1310 nm, say, and assuming 1 dB for various in line connector losses, then the maximum distance that can be run is 100 km  $((31\text{dB}-1\text{dB})/0.3\text{dBkm}^{-1})$ .

The HDR-4611 receiver module accepts an input optical signal with a power level in the range of -5 dBm to -31 dBm. A red LED 'Optical Fail' indicator on the front panel, and a relay alarm accessible by the rear assembly, indicates when the optical path loss has exceeded the maximum 31 dB allowed.

The output of the HDR-4611 receiver is the same signal that was originally inputted to the HDT-4611 transmitter. A front panel green LED, and a relay alarm accessible by the rear assembly, indicates the presence of a valid locked output signal. Another green LED indicates whether the received signal is an HD type of signal, or a yellow LED indicates whether the received signal is an SD type of signal.

# SNMP

## What Is It?

SNMP stands for Simple Network Management Protocol. It is an application layer protocol for managing IP (Internet Protocol) based systems. SNMP enables system administrators to manage system performance, and to find and solve system problems. SNMP runs over UDP (User Datagram Protocol), which in turn runs over IP.

Three types of SNMP exist: SNMP version 1 (SNMPv1), SNMP version 2 (SNMPv2) and SNMP version 3 (SNMPv3). It is not the intention here to discuss the differences between various versions, only to bring attention to the fact that IRT Electronics modules, fitted with SNMP capability, use SNMPv1.

An SNMP managed network consists of three key components: Network Management Systems (*NMS*), *agents*, and *managed devices*.

An *NMS* is the console through which the network administrator performs network management functions, such as monitoring status (e.g. alarm states) and remote controlling, of a set of managed devices. One or more *NMS*s must exist on any managed network. Generally the *NMS* is a computer running third party SNMP control software. There are a number of third party SNMP software applications currently available on the market.

An *NMS* polls, or communicates with, an *agent*. An *agent* is a network management software module that resides in a *managed device*. An *agent* has local knowledge of management information and translates that information into a form compatible with SNMP. The *agent*, therefore, acts as an interface between the *NMS* and the managed devices. The *NMS* sends a request message, and control commands for the managed devices, to the *agent*, which in turn sends a response message, containing information about the *managed devices*, back to the *NMS*.

A *managed device* contains an SNMP *agent* and resides on a managed network. *Managed devices* collect and store management information and make this information available to *NMS*s using SNMP.

*Managed device agent* variables are organised in a tree structure known as a Management Information Base (*MIB*). Within the *MIB* are parameters pertaining to the *managed device*. An Object Identifier (OID) number within the *MIB* defines the managed device type. This is a unique number specific to the model of *managed device*. Other information relating to the device is also stored, information such as alarm states, controllable settings, etc. The *MIB* tree is organised in such a way that there will be no two *MIB* files with conflicting placements.

Normally an *NMS* polls an *agent* for information relating to the *MIB* in a managed device to be sent back to the *NMS*. When certain conditions are met within the *MIB*, such as major alarm conditions, for example, the *agent* automatically sends what is known as a *trap* to the *NMS* without any prompting from the *NMS*. This allows automatic notification of a predetermined event.

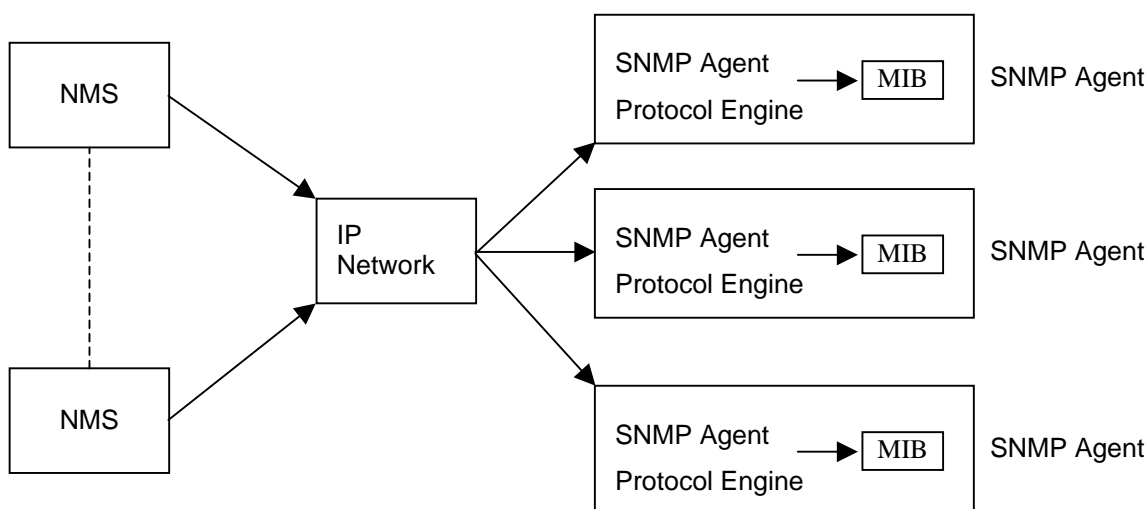

**SNMP with IRT Products:**

IRT Electronics currently employs SNMPv1 with its SNMP capable frames. The frame acts as an *agent* when fitted with a CDM-xxxx module. This module has its own designated slot next to the power supply so as to not affect the number of modules that the frame will take. Communication between the *NMS*, the frame and its loaded modules are via this CDM-xxxx module. Note that the *NMS* software is third party and not supplied by IRT Electronics.

Ethernet connection for SNMP operation is via an RJ45 connector on the rear of the frame, below the mains inlet. Ethernet rate runs at either 10 baseT or 100 baseT.

Frame parameters, such as Name, Address and Location, are set via an RS232 interface, a D9 connector on the rear of the frame below the mains inlet. A software terminal emulator, such as Tera Term or HyperTerminal, is used for setting and reading the parameters of the frame.

IRT modules that are SNMP compatible need a plug-in SMU-4000 module with a program relevant to the module that it is plugged into. Depending on the module, besides the module identification, parameters such as alarm states, inputs and controls etc. are communicated to the CDM-xxxx *agent* via a data bus on the rear of the frame. Thus the CDM-xxxx collects information on what is loaded within the frame, what positions they occupy, and their current status for communication to the *NMS* when the *NMS* sends a request for information.

In the event of a major alarm from any of the SNMP compatible modules, or power supplies, a *trap* is automatically sent by the CDM-xxxx *agent* to the *NMS* without any prompting by the *NMS*. This alerts the operator to any fault conditions that may exist that need immediate attention.

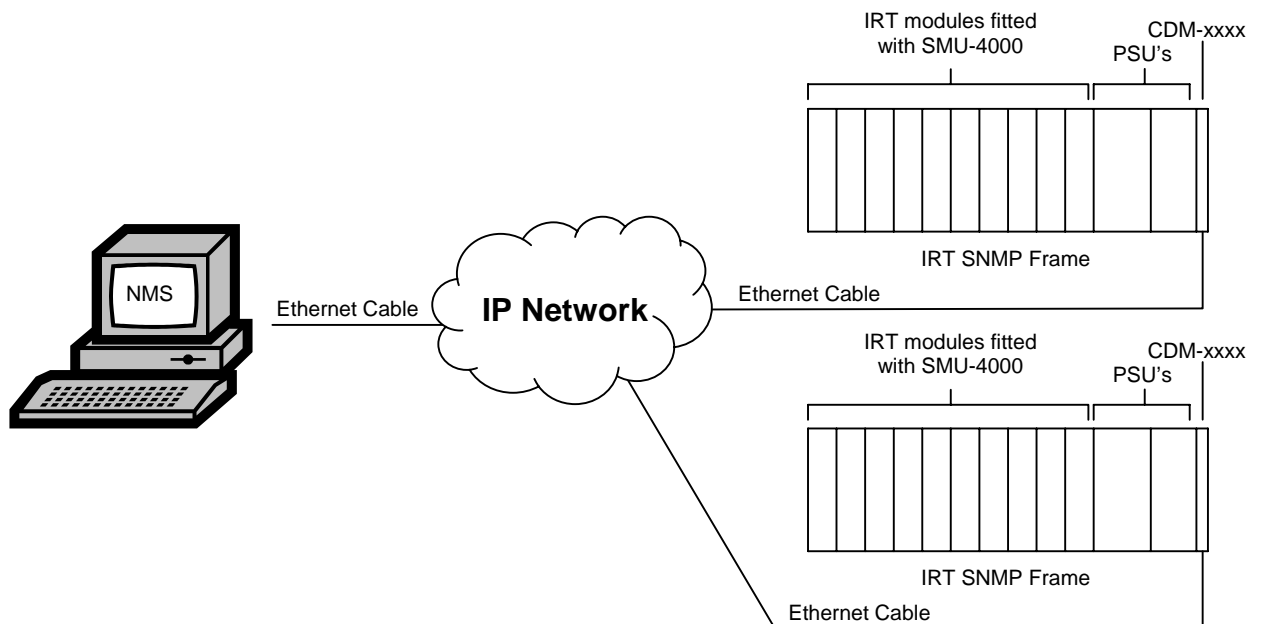
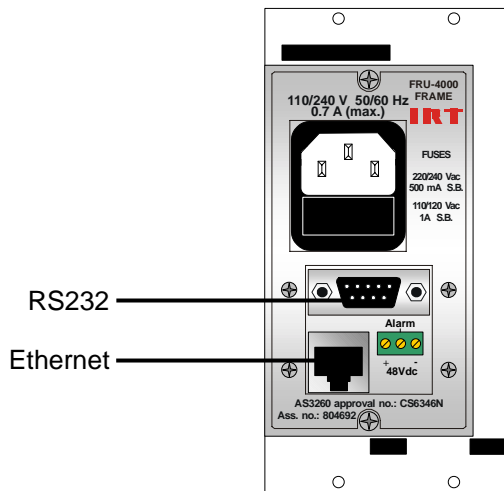

**IRT SNMP Setup**

## **HDT-4611 & HDR-4611 SNMP Functions:**

With the HDT-4611/HDR-4611 fitted with the optional plug-in SMU-4000 SNMP module, programmed with the firmware to suit and installed in an IRT 4000 series frame with SNMP capability, these can be interrogated by an SNMP Network Management System (NMS).

The following SNMP functions are capable of being monitored by an NMS:

### **HDT-4611:**

- An indication that an input signal is present;
- An indication that there is an output from the Laser;
- An indication of the Laser wavelength;
- An indication of the state of the laser enable control as well as being able to enable via SNMP;
- An indication of the light level output;
- Whether "Trap" function is enabled;
- An indication of the cause of the Trap;
- Trap automatically sent, if enabled, on "Urgent" alarm;
- Trap automatically sent, if enabled, if "Urgent" alarm clears; and
- Unit reset control.

### **HDR-4611:**

- An indication that an encoded signal has been detected and whether it is an HD signal;
- An indication that there is an optical input;
- An indication of the type of optical detector installed;
- An indication of the light level input;
- Whether "Trap" function is enabled;
- An indication of the cause of the Trap;
- Trap automatically sent, if enabled, on "Urgent" alarm;
- Trap automatically sent, if enabled, if "Urgent" alarm clears; and
- Unit reset control.

# Installation

## Pre-installation:

### Handling:

This equipment may contain or be connected to static sensitive devices and proper static free handling precautions should be observed.

Where individual circuit cards are stored, they should be placed in antistatic bags. Proper antistatic procedures should be followed when inserting or removing cards from these bags.

### Power:

AC mains supply: Ensure that operating voltage of unit and local supply voltage match and that correct rating fuse is installed for local supply.

DC supply: Ensure that the correct polarity is observed and that DC supply voltage is maintained within the operating range specified.

### Earthing:

The earth path is dependent on the type of frame selected. In every case particular care should be taken to ensure that the frame is connected to earth for safety reasons. See frame manual for details.

**Signal earth:** For safety reasons a connection is made between signal earth and chassis earth. No attempt should be made to break this connection.

## Installation in frame or chassis:

See details in separate manual for selected frame type.

## Signal connections:

The HDT-4611 and HDR-4611 are set up to operate at either **1.485 Gb/s HD** or **270 Mb/s SD** signals and do not require any adjustment prior to use, with the exception of a slew rate link setting for HD or SD on the monitoring output of the HDT-4611. There are no external controls on the front panel of the units.

Optical connections are made to the panel adapter mounted on a bracket at the rear of the modules. Care must be taken to provide a clean surface on the optical connectors and in inserting the plug on the external fibre to prevent damage to the alignment ferrule of the panel adapter. Type of fibre used must be single mode type.

The serial digital signal connections are made to the BNC connectors on the rear panel.

The external alarm contact connections are made to the 4 pin parallel wired connectors at the bottom of the rear panel.

The connections are:	HDT-4611	SK4/4A	pin 4	dc power fail
			pin 3	laser fail/laser off
			pin 2	digital signal loss
			pin 1	ground
	HDR-4611	SK5/6	pin 4	dc power fail
			pin 3	optical low/optical loss
			pin 2	digital signal loss
			pin 1	ground

The presence of the internal DC supply voltage is indicated by the front panel **DC** LED (green).

## Front & rear panel connector diagrams

The following front panel and rear assembly drawings are not to scale and are intended to show connection order and approximate layout only.

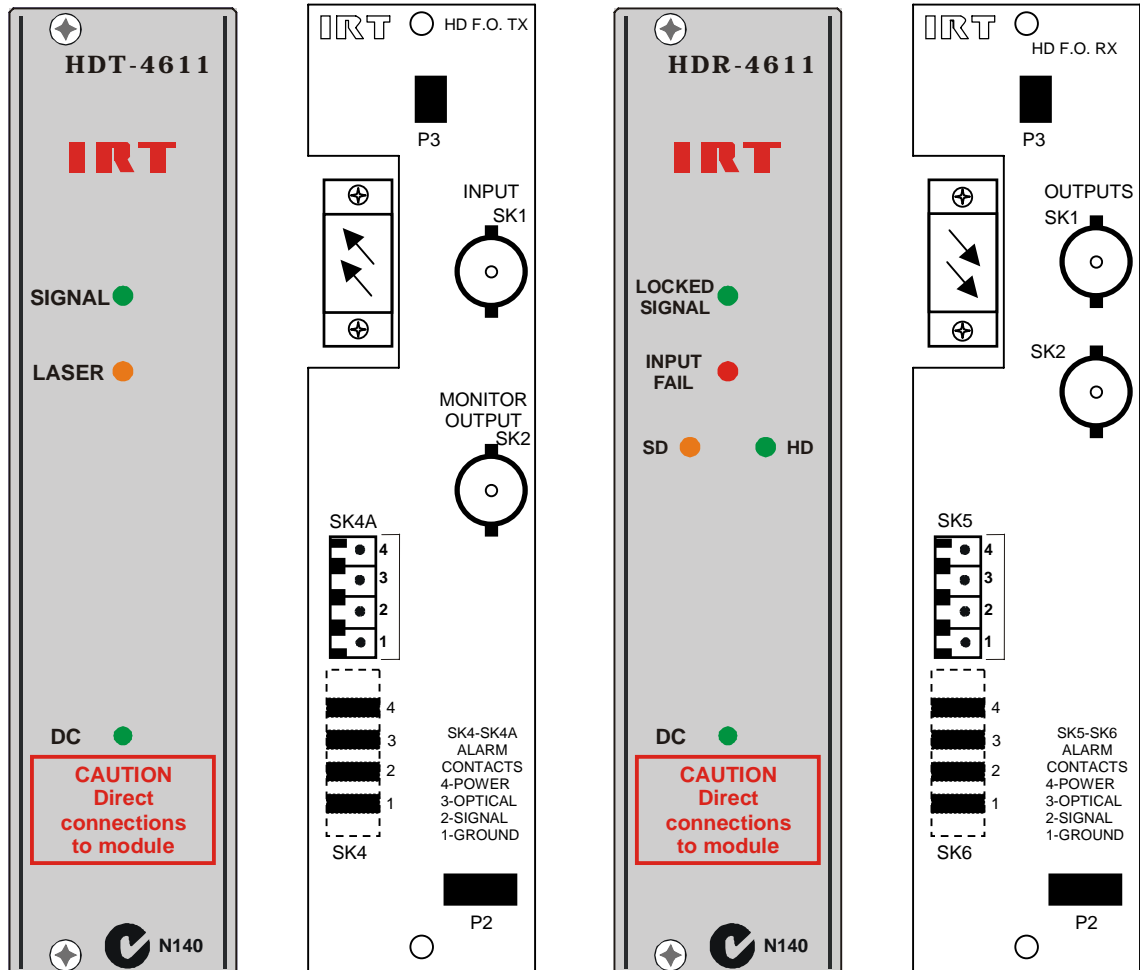

## Maintenance & Storage

### Maintenance:

No regular maintenance is required.

Care however should be taken to ensure that all connectors are kept clean and free from contamination of any kind. This is especially important in fibre optic equipment where cleanliness of optical connections is critical to performance.

### Storage:

If the equipment is not to be used for an extended period, it is recommended the whole unit be placed in a sealed plastic bag to prevent dust contamination. In areas of high humidity a suitably sized bag of silica gel should be included to deter corrosion.

Where individual circuit cards are stored, they should be placed in antistatic bags. Proper antistatic procedures should be followed when inserting or removing cards from these bags.

## Warranty & Service

Equipment is covered by a limited warranty period of three years from date of first delivery unless contrary conditions apply under a particular contract of supply. For situations when “**No Fault Found**” for repairs, a minimum charge of 1 hour’s labour, at IRT’s current labour charge rate, will apply, whether the equipment is within the warranty period or not.

Equipment warranty is limited to faults attributable to defects in original design or manufacture. Warranty on components shall be extended by IRT only to the extent obtainable from the component supplier.

### Equipment return:

Before arranging service, ensure that the fault is in the unit to be serviced and not in associated equipment. If possible, confirm this by substitution.

Before returning equipment contact should be made with IRT or your local agent to determine whether the equipment can be serviced in the field or should be returned for repair.

The equipment should be properly packed for return observing antistatic procedures.

The following information should accompany the unit to be returned:

1. A fault report should be included indicating the nature of the fault
2. The operating conditions under which the fault initially occurred.
3. Any additional information, which may be of assistance in fault location and remedy.
4. A contact name and telephone and fax numbers.
5. Details of payment method for items not covered by warranty.
6. Full return address.
7. For situations when “**No Fault Found**” for repairs, a minimum charge of 1 hour’s labour will apply, whether the equipment is within the warranty period or not. Contact IRT for current hourly rate.

Please note that all freight charges are the responsibility of the customer.

The equipment should be returned **to the agent who originally supplied the equipment** or, where this is not possible, to IRT direct as follows.

Equipment Service  
IRT Electronics Pty Ltd  
26 Hotham Parade  
ARTARMON  
N.S.W. 2064  
AUSTRALIA

Phone: 61 2 9439 3744

Fax: 61 2 9439 7439

Email: [service@irtelectronics.com](mailto:service@irtelectronics.com)

## Drawing Index

Drawing #	Sheet #	Description
805027	1	HDT-4611 serial digital fibre optic transmitter schematic diagram.
805086	1	HDR-4611 serial digital fibre optic receiver schematic diagram.

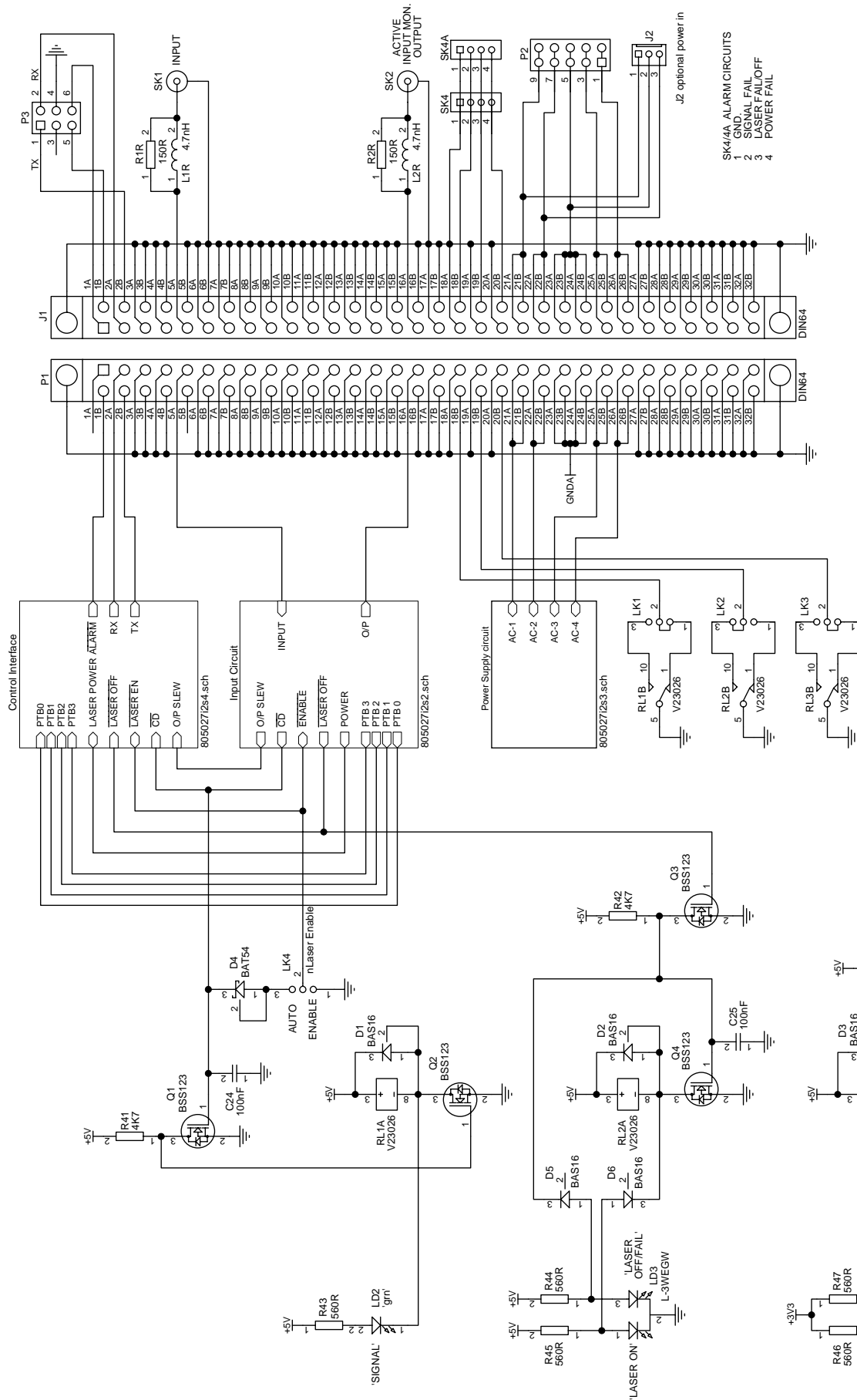

- SK4/4A ALARM CIRCUITS
- 1 GND.
  - 2 SIGNAL FAIL
  - 3 LASER FAIL/FF
  - 4 POWER FAIL

J2 optional power in

Relay contacts shown "NOT ENERGISED"

COPYRIGHT DO NOT COPY NOR DISTRIBUTE ANY THIRD PARTY WITHOUT WRITTEN CONSENT	
SIZE A3	Title HDT-4610/HDT-4611 HDS/D OPTICAL TX
CHECKED ENG. APP.	DRAWN K.N.
SCALE N.T.S.	Drawing No 605027
Date: 8-Jul-2008	Revision: 2
ARTARMON NSW AUSTRALIA 2064	

- 1 27-02-2007
- 2 18-09-2007

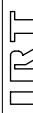

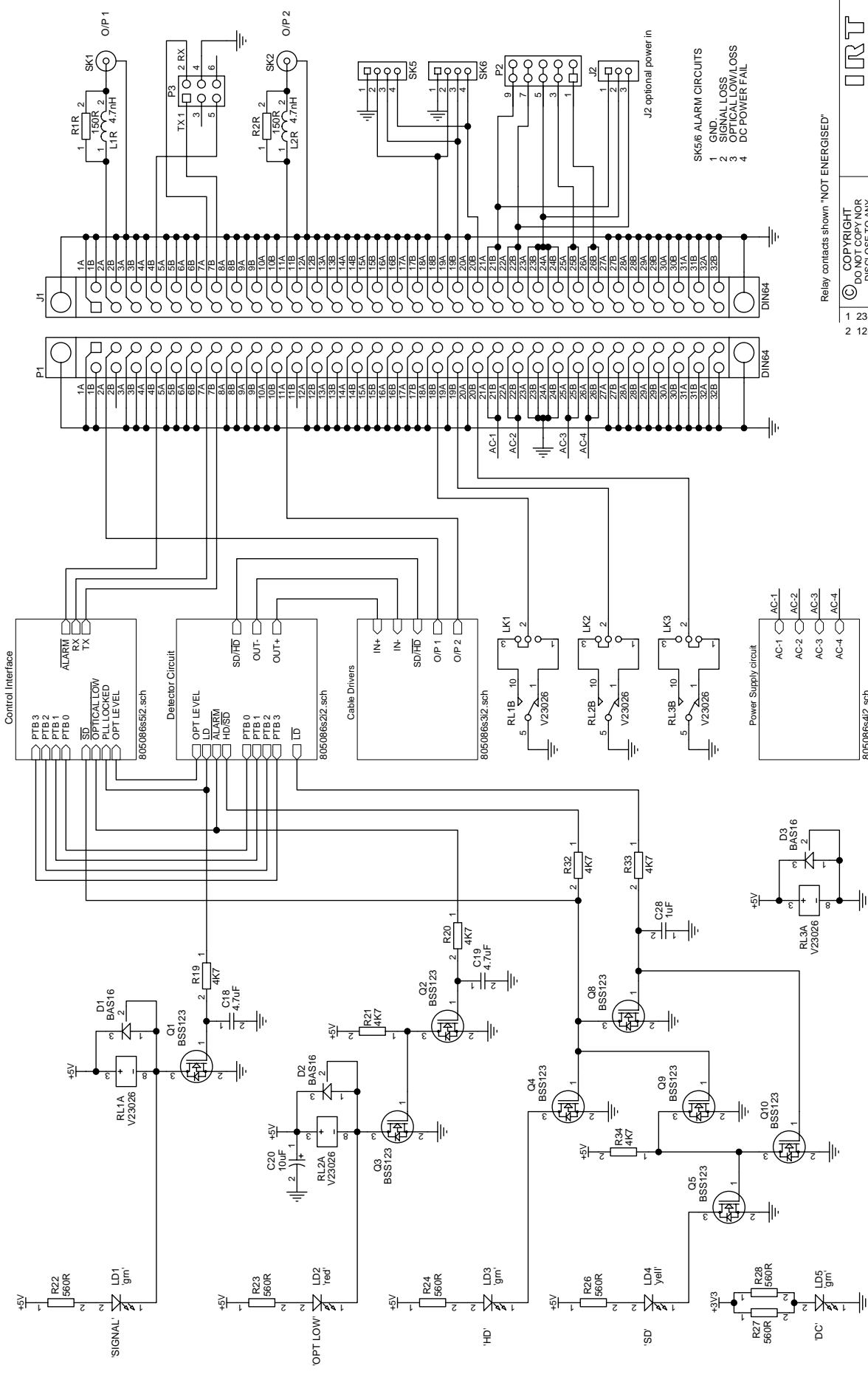

Relay contacts shown "NOT ENERGISED"

COPYRIGHT DO NOT COPY NOR REPRODUCE IN ANY MANNER WITHOUT WRITTEN CONSENT	
1 23-05-2006	2 12-10-2006
DRAWN K.N.	CHECKED
ENG. APP.	Revision: 2
Scale N.T.S.	Date: 8-Jul-2008
SIZE A3	Title HDR-4610HDR-4611
SCALE	Drawing N805086
Sheet 1 of 5	IRT Electronics Pty. Ltd.
	ARTARMON NSW AUSTRALIA 2064



Relay contacts shown "NOT ENERGISED"

COPYRIGHT DO NOT COPY NOR REPRODUCE IN ANY MANNER WITHOUT WRITTEN CONSENT	
1 23-05-2006	2 12-10-2006
DRAWN K.N.	CHECKED
ENG. APP.	Revision: 2
Scale N.T.S.	Date: 8-Jul-2008
SIZE A3	Title HDR-4610HDR-4611
SCALE	Drawing N805086
Sheet 1 of 5	IRT Electronics Pty. Ltd.
	ARTARMON NSW AUSTRALIA 2064