



IRT Electronics Pty Ltd A.B.N. 35 000 832 575
26 Hotham Parade, ARTARMON N.S.W. 2064 AUSTRALIA
National: Phone: (02) 9439 3744 Fax: (02) 9439 7439
International: +61 2 9439 3744 +61 2 9439 7439
Email: sales@irtelectronics.com
Web: www.irtelectronics.com

IRT Eurocard

Type MMM-4681 & MMX-4681

**4 ASI to STM-1
Combiner / DeCombiner**

Designed and manufactured in Australia

**IRT can be found on the Internet at:
<http://www.irtelectronics.com>**

IRT Eurocard
Type MMM-4681 & MMX-4681

4 ASI to STM-1
Combiner / DeCombiner

Instruction Book

Table of Contents

Section	Page
Operational Safety	2
General Description	3
Technical Specifications	4
Configuration	5
Installation	6
Front and rear layouts	10
SNMP – What Is It?	11
MMM-4681 & MMX-4681 SNMP Functions	13
Maintenance & Storage	14
Warranty & Service	14
Equipment return	14

This instruction book applies to units later than S/N 0807001.

Operational Safety:

WARNING

Operation of electronic equipment involves the use of voltages and currents that may be dangerous to human life. Note that under certain conditions dangerous potentials may exist in some circuits when power controls are in the **OFF** position. Maintenance personnel should observe all safety regulations.

Do not make any adjustments inside equipment with power **ON** unless proper precautions are observed. All internal adjustments should only be made by suitably qualified personnel. All operational adjustments are available externally without the need for removing covers or use of extender cards.

IRT Eurocard Type MMM-4681 & MMX-4681 4 ASI to STM-1 Combiner / DeCombiner

General Description

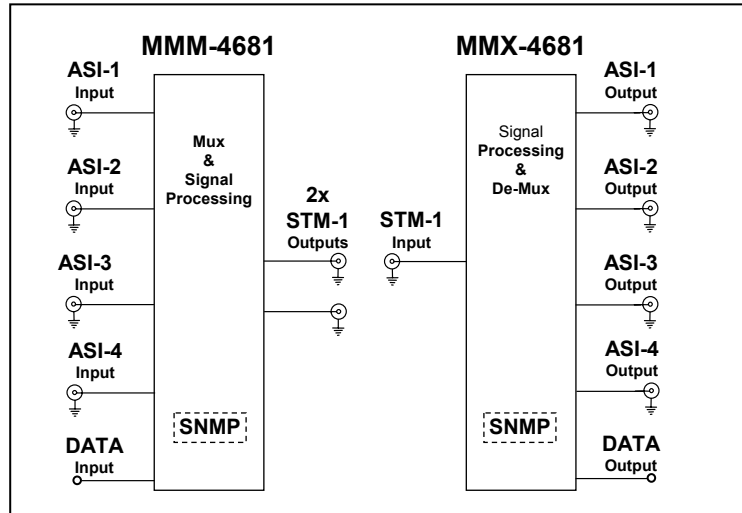

The MMM-4681 and MMX-4681 are part of a family of data transcoders for converting between the commonly used MPEG2 Transport Stream formats for video distribution in the broadcast industry.

With the MMM-4681 up to four ASI and one RS232 data signal can be combined together and converted into a 155Mb/s G.703 (STM-1) electrical CMI signal, or NRZ standard (NRZ for optically interfacing to an STM-1 optical fibre network using IRT's DDT-4210/DDR-4211 fibre link set to match corresponding rate for transmission).

The sum of the ASI input payload rates can be anything up to 148 Mb/s. Inputs may be 188 or 204 byte packet length, burst or continuous, and may have energy dispersal scrambling, interleaving and/or Reed Solomon bytes included.

The MMX-4681 separates the 155 Mb/s G.703 signal back into the original four ASI signals (at their original rates) and the RS232 data signal. The ASI outputs are suitable for Single Frequency Network use, in that there is no data rate conversion or PCR restamping of the ASI streams.

Inputs are automatically equalised for lengths of up to 250m of Belden 8281 or equivalent cable.

RS232 uni-directional data may also be sent on the same link. It can pass rates up to 19.2 kb/s with any combination of start/stop & parity bits. The data rate does not affect the payload available for the ASI streams.

Front panel indication and relay alarm on the MMM-4681 transmitter shows if there is an input data rate violation. Corresponding alarm on the MMX-4681 receiver shows a loss of STM-1 input.

Optional SNMP (Simple Network Management Protocol) version is available for monitoring and control when used in an IRT frame fitted with SNMP capability.

The MMM-4681 and MMX-4681 are designed to fit IRT's standard Eurocard frames and may be used alongside any other of IRT's analogue or digital Eurocards.

Standard features:

- Up to 4 ASI and 1 Data stream on one 155 Mb/s (STM-1) G.703 electrical or optical¹ link
- Automatic Input equalisation up to 250m
- Suitable for Single Frequency Network (SFN) use
- Recovers transmitted ASI signal with minimal user setup
- Maintains original ASI rate, packet size & coding (energy dispersal scrambling, interleaving or Reed Solomon bytes)
- Eurocard format

¹ When used in conjunction with IRT's DDT-4210/DDR-4211 fibre link set to match corresponding rate.

Technical Specifications

MMM-4681:

Inputs:

Type 1	4 x ASI-C 75 Ω , 800 mVp-p, BNC connector.
Maximum Data Rate per channel	Up to a combined maximum rate of 148 Mb/s
Type 2	RS232 Uni directional data input.

Output:

Type	2 x 800mVp-p, G.703, 75 Ω BNC connector.
Electrical Characteristics	CMI (STM-1e) or NRZ (STM-1o) encoded, selectable.
Data Rate	155.52 Mb/s.

Alarm Output:	MAJOR	Open circuit on sum of ASI input payload rates in excess of maximum allowable 148Mb/s, or loss of power.
	MINOR	Open circuit on no valid input ASI streams present, or loss of power.

MMX-4681:

Input:

Type	1 x G.703, 75 Ω BNC connector.
Electrical Characteristics	CMI (STM-1e) or NRZ (STM-1o) encoded, selectable.
Data Rate	155.52 Mb/s.

Outputs:

Type 1	4 x ASI-C 75 Ω , 800 mVp-p, BNC connector.
Data Rate	same as MMM-4681 input rate.
Type 2	RS232 Uni directional data output.

Alarm Output:	MAJOR	Open circuit on no valid STM-1 input present, or loss of power.
	MINOR	Open circuit on no valid output ASI streams present, or loss of power.

Power Requirements

Power consumption	28 Vac CT (14-0-14) or ± 16 Vdc. 6 VA.
-------------------	---

Other

Temperature range	0 - 50 $^{\circ}$ C ambient.	
Mechanical	Suitable for mounting in IRT 19" rack chassis with input, output and power connections on the rear panel.	
Finish	Front panel	Grey, silk-screened black lettering & red IRT logo.
	Rear assembly	Detachable silk-screened PCB with direct mount connectors to Eurocard and external signals.
Dimensions	6 HP x 3 U x 220 mm IRT Eurocard.	

Due to our policy of continuing development, these specifications are subject to change without notice.

Configuration

MMM-4681:

The only user settings on the MMM-4681 is on the DIP switch SW4 as shown below:

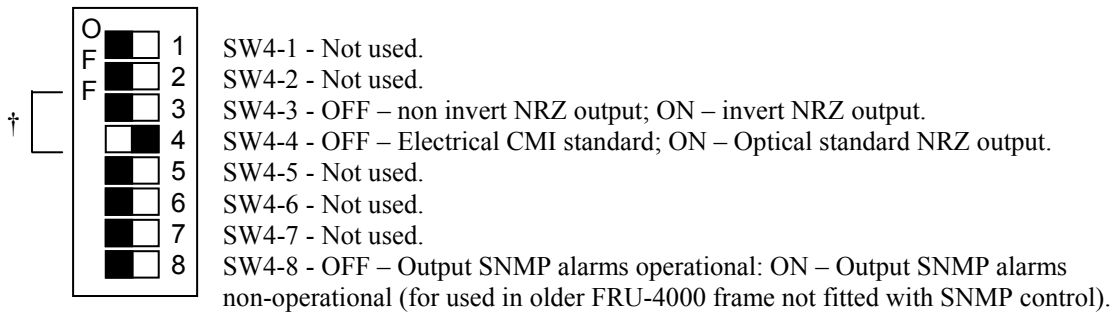

MMX-4681:

The only user settings on the MMX-4681 is on the DIP switch SW4 as shown below:

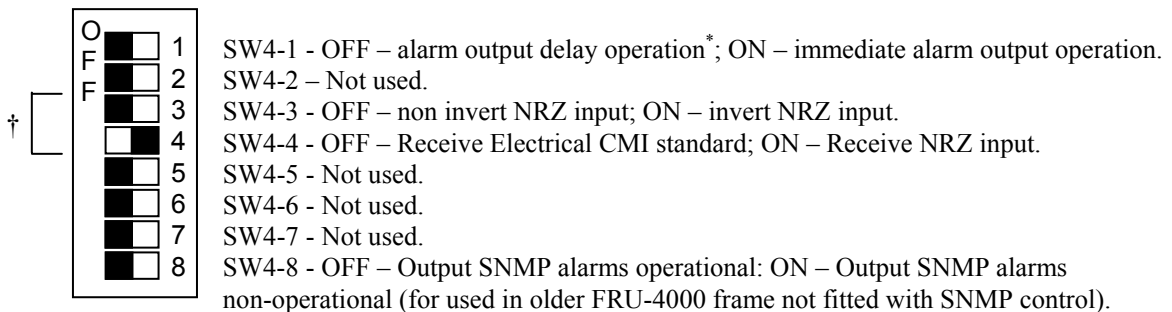

NOTE: * - with alarm output delay operation set, alarm will only activate approximately 3 seconds after initial alarm condition if alarm condition is still valid.

† SW4-4 position must be the same for both MMM-4681 and MMX-4681 cards.
SW4-3 position generally must be the same for both MMM-4681 and MMX-4681, but depends on interface equipment that the MMM-4681 is feeding and the MMX-4681 is being fed from on whether inversion is necessary or not. If link fails to operate, first check that SW4-4 of both MMM-4681 and MMX-4681 match and are in correct position, and then position of SW4-3 on both cards. SW4-3 operation is only valid for NRZ operation.

Installation

Pre-installation:

Handling:

This equipment may contain or be connected to static sensitive devices and proper static free handling precautions should be observed.

Where individual circuit cards are stored, they should be placed in antistatic bags. Proper antistatic procedures should be followed when inserting or removing cards from these bags.

Power:

AC mains supply: Ensure that operating voltage of unit and local supply voltage match and that correct rating fuse is installed for local supply.

DC supply: Ensure that the correct polarity is observed and that DC supply voltage is maintained within the operating range specified.

Earthing:

The earth path is dependent on the type of frame selected. In every case particular care should be taken to ensure that the frame is connected to earth for safety reasons. See frame manual for details.

Signal earth: For safety reasons a connection is made between signal earth and chassis earth. No attempt should be made to break this connection.

Installation in frame or chassis:

See details in separate manual for selected frame type.

Connections:

MMM-4681:

ASI Inputs:

Four ASI inputs each with any payload to a combined maximum total payload of 148 Mb/s. That is,

$$\text{Total payload (148Mb/s maximum)} = \text{ASI 1 rate} + \text{ASI 2 rate} + \text{ASI 3 rate} + \text{ASI 4 rate}$$

WARNING: If the total maximum payload rate is exceeded, all ASI channels will be corrupted unless channel capping has been set via SNMP control.

ASI inputs may be of 188 or 204 byte packet length, burst or continuous mode, and may have scrambling / interleaving and Reed Solomon bytes if desired.

ASI inputs are by BNC connectors each terminated in 75Ω. Input cable equalisation is automatic for up to 250m of high quality 75Ω coaxial cable (Belden 8281 or equivalent). No adjustments are required.

STM-1 Outputs:

Two identical STM-1 CMI (equivalent to STM-1 electrical standard) or NRZ (equivalent to STM-1 optical standard, in an electrical form) outputs are provided by BNC connectors with a 75Ω characteristic output impedance. Only high quality 75Ω coaxial cable (Belden 8281 or equivalent) should be used. No adjustments are required, but cable must be terminated in 75Ω at the connected load.

Alarm Outputs:

Two relay alarm output states are provided via a phoenix style 4-pin plug. Pin 3 is designated as Major, pin 4 is designated as Minor, and both pins 1 & 2 are ground. Both alarms are referenced to ground.

Alarm conditions are as follows:

- Major switch to Open Circuit on sum of ASI input payload rates in excess of maximum allowable 148Mb/s;
 - Minor switch to Open Circuit on no valid input ASI streams present.
- Both Major and Minor alarms switch to Ground on power failure.

MMM-4681
Rear Assembly Connections

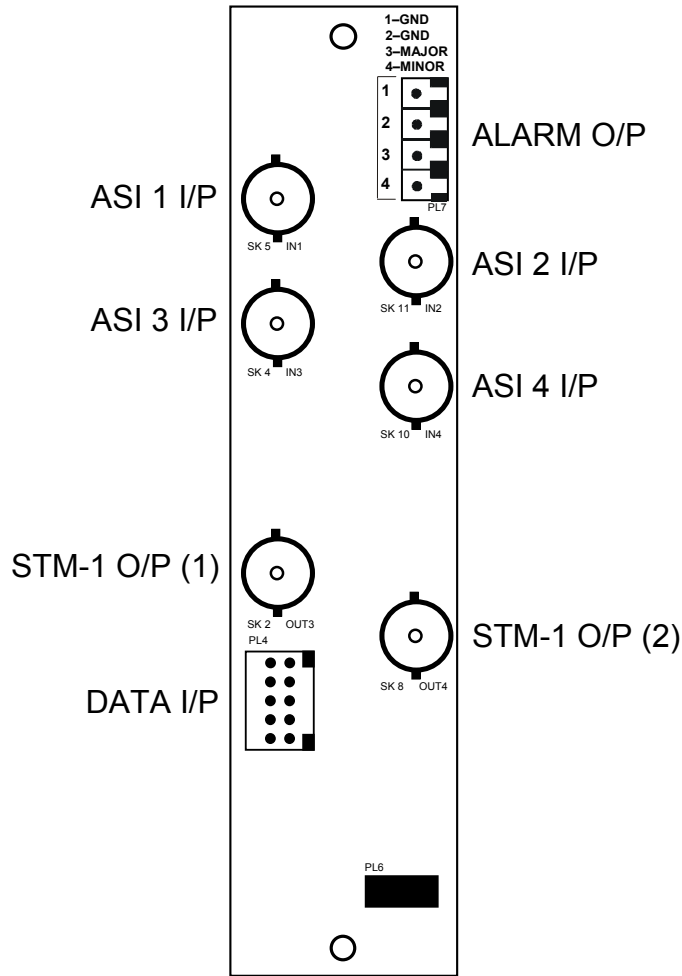

RS-232 Data Input:

The RS-232 data input port is via a 10 pin HE14 style of header. Pins 1, 2 and 7 are connected together on the PCB. Pins 9 and 10 are both earthed. Pin 3 is the RS-232 *receive data* (RXD) connection. Data rates may be up to 19k2 Baud. Note that data transfer is unidirectional only, i.e. there is no direct data return path.

For connection to a standard RS-232 9 pin D connector, wire as per the diagram below:

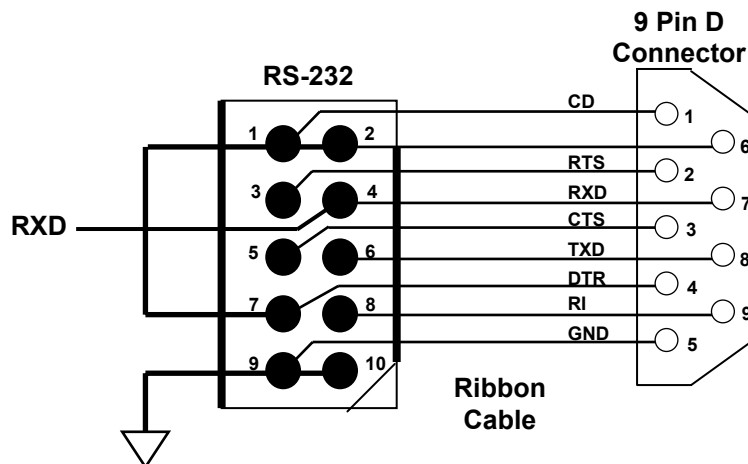

MMX-4681:

STM-1 Input:

The STM-1 input port on the rear assembly is a 75Ω terminated BNC connector for an MMM-4681 encoded signal only. Use of high quality 75Ω coaxial cable (Belden 8281 or equivalent) is recommended.

ASI Outputs:

Four ASI outputs are provided as 75Ω output BNC connectors. Each ASI output has a payload rate and packet size equivalent to the corresponding ASI input on the matching MMM-4681.

Alarm Outputs:

Two relay alarm output states are provided via a phoenix style 4-pin plug. Pin 3 is designated as Major, pin 4 is designated as Minor, and both pins 1 & 2 are ground. Both alarms are referenced to ground.

Alarm conditions are as follows:

- Major switch to Open Circuit on no valid STM-1 input present;
- Minor switch to Open Circuit on no valid output ASI streams present.
- Both Major and Minor alarms switch to Ground on power failure.

MMX-4681 Rear Assembly Connections

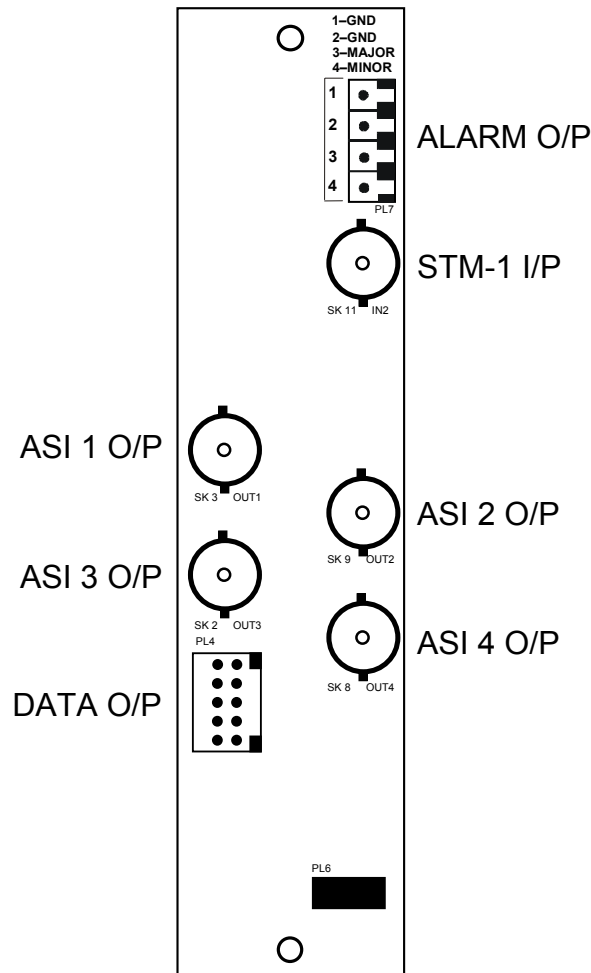

RS-232 Data Output

The RS-232 data output port is via a 10 pin HE14 style of header. Pins 1, 2 and 7 are connected together on the PCB. Pins 9 and 10 are both earthed. Pin 5 is the RS-232 *transmit data* (TXD) connection. Data transfer is unidirectional only, this is a receive path only.

For connection to a standard RS-232 9 pin D connector, wire as per the diagram below:

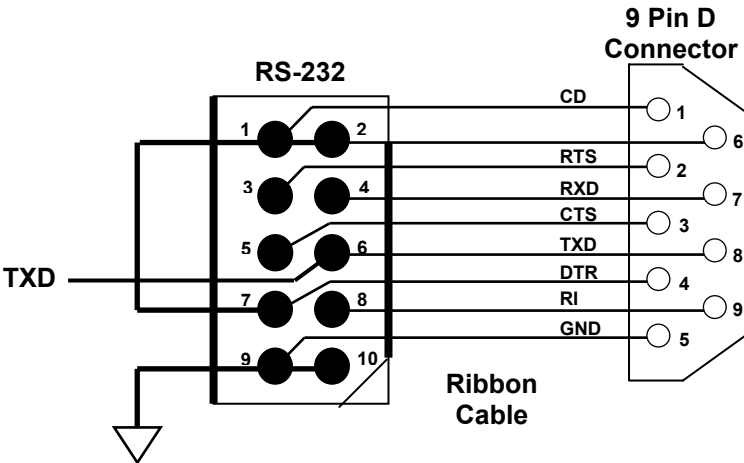

Front & rear panel connector diagrams

The following front panel and rear assembly drawings are not to scale and are intended to show connection order and approximate layout only.

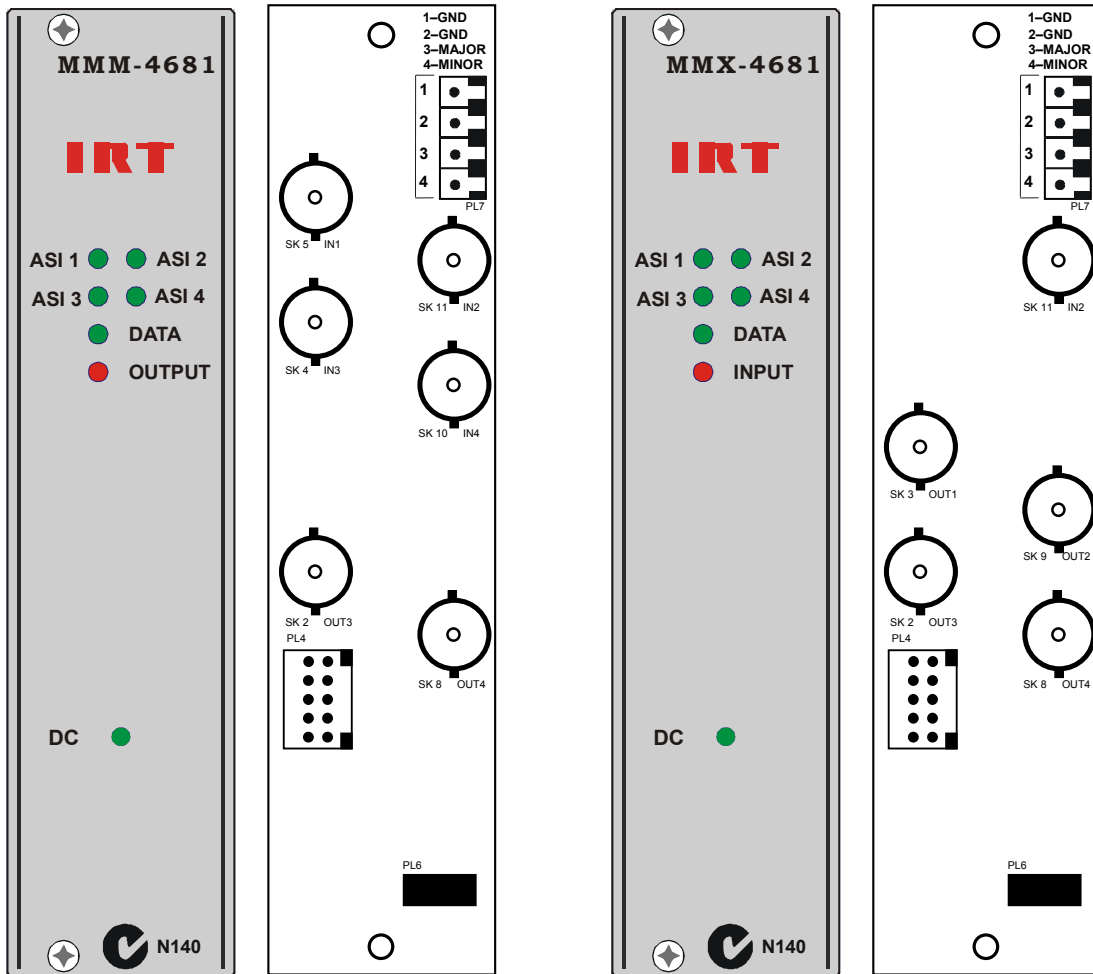

SNMP

What Is It?

SNMP stands for Simple Network Management Protocol. It is an application layer protocol for managing IP (Internet Protocol) based systems. SNMP enables system administrators to manage system performance, and to find and solve system problems. SNMP runs over UDP (User Datagram Protocol), which in turn runs over IP.

Three types of SNMP exist: SNMP version 1 (SNMPv1), SNMP version 2 (SNMPv2) and SNMP version 3 (SNMPv3). It is not the intention here to discuss the differences between various versions, only to bring attention to the fact that IRT Electronics modules, fitted with SNMP capability, use SNMPv1.

An SNMP managed network consists of three key components: Network Management Systems (*NMS*), *agents*, and *managed devices*.

An *NMS* is the console through which the network administrator performs network management functions, such as monitoring status (e.g. alarm states) and remote controlling, of a set of managed devices. One or more *NMS*s must exist on any managed network. Generally the *NMS* is a computer running third party SNMP control software. There are a number of third party SNMP software applications currently available on the market.

An *NMS* polls, or communicates with, an *agent*. An *agent* is a network management software module that resides in a *managed device*. An *agent* has local knowledge of management information and translates that information into a form compatible with SNMP. The *agent*, therefore, acts as an interface between the *NMS* and the managed devices. The *NMS* sends a request message, and control commands for the managed devices, to the *agent*, which in turn sends a response message, containing information about the *managed devices*, back to the *NMS*.

A *managed device* contains an SNMP *agent* and resides on a managed network. *Managed devices* collect and store management information and make this information available to *NMS*s using SNMP.

Managed device agent variables are organised in a tree structure known as a Management Information Base (*MIB*). Within the *MIB* are parameters pertaining to the *managed device*. An Object Identifier (OID) number within the *MIB* defines the managed device type. This is a unique number specific to the model of *managed device*. Other information relating to the device is also stored, information such as alarm states, controllable settings, etc. The *MIB* tree is organised in such a way that there will be no two *MIB* files with conflicting placements.

Normally an *NMS* polls an *agent* for information relating to the *MIB* in a managed device to be sent back to the *NMS*. When certain conditions are met within the *MIB*, such as major alarm conditions, for example, the *agent* automatically sends what is known as a *trap* to the *NMS* without any prompting from the *NMS*. This allows automatic notification of a predetermined event.

SNMP Block Diagram

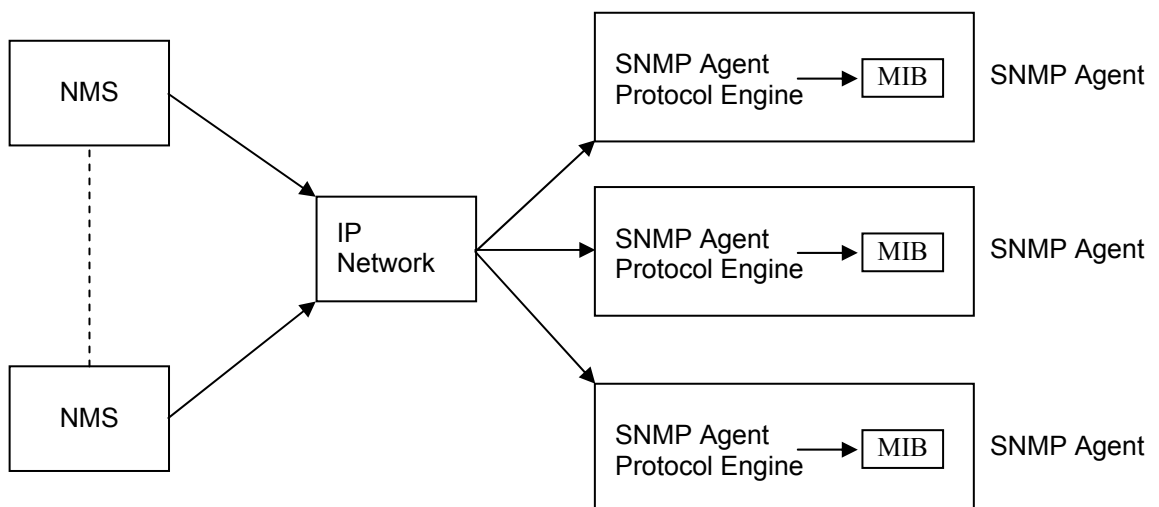

SNMP with IRT Products:

IRT Electronics currently employs SNMPv1 with its SNMP capable frames. The frame acts as an *agent* when fitted with a CDM-xxxx module. This module has its own designated slot next to the power supply so as to not affect the number of modules that the frame will take. Communication between the *NMS*, the frame and its loaded modules are via this CDM-xxxx module. Note that the *NMS* software is third party and not supplied by IRT Electronics.

Ethernet connection for SNMP operation is via an RJ45 connector on the rear of the frame, below the mains inlet. Ethernet rate runs at either 10 baseT or 100 baseT.

Frame parameters, such as Name, Address and Location, are set via an RS232 interface, a D9 connector on the rear of the frame below the mains inlet. A software terminal emulator, such as Tera Term or HyperTerminal, is used for setting and reading the parameters of the frame.

IRT modules that are SNMP compatible need a plug-in SMU-4000 module with a program relevant to the module that it is plugged into. Depending on the module, besides the module identification, parameters such as alarm states, inputs and controls etc. are communicated to the CDM-xxxx *agent* via a data bus on the rear of the frame. Thus the CDM-xxxx collects information on what is loaded within the frame, what positions they occupy, and their current status for communication to the *NMS* when the *NMS* sends a request for information.

In the event of a major alarm from any of the SNMP compatible modules, or power supplies, a *trap* is automatically sent by the CDM-xxxx *agent* to the *NMS* without any prompting by the *NMS*. This alerts the operator to any fault conditions that may exist that need immediate attention.

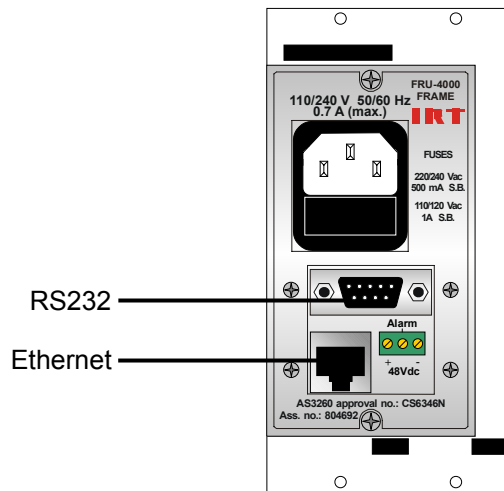

IRT SNMP Connections

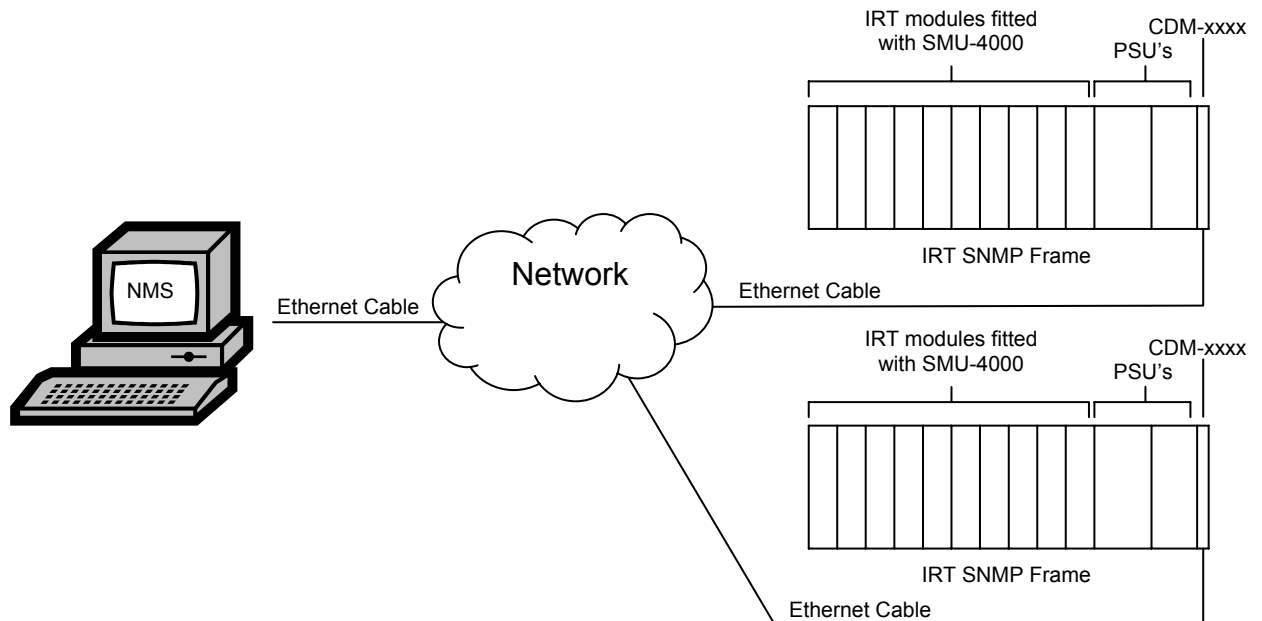

IRT SNMP Setup

MMM-4681 & MMX-4681 SNMP Functions:

With the MMM-4681 and MMX-4681 loaded with the optional SNMP firmware, an SNMP Network Management System (NMS) can interrogate and control modules.

The following SNMP functions are capable of being controlled and monitored by an NMS:

MMM-4681:

- The current state of the Urgent and Non Urgent Alarms;
- Allows bandwidth capping to be enabled or disabled;
- Information about each channel:
 - An indication that the channel input signal is present;
 - An indication whether the channel is enabled or not[†]. Can be remotely set for enabled or not enabled[†].
 - An indication of the packet size;
 - An indication of the approximate data rate;
 - The maximum allowed data rate of each channel. Can be remotely set*.
 - An indication that the data rate is too high for the channel assignment;
 - A 15 byte maximum Alias (name) for the channel can be read and set;
- An indication of the jumper selected (SW4-4) configuration for the output – CMI, NRZ, or inverted NRZ;
- The software version of the main FPGA in the format 'x.y', where x is the major rev. no. and y the minor.
- Whether "Trap" functions are enabled;
- Trap automatically sent, if enabled, on Urgent and Non Urgent alarms occurring and when they clear;
- Trap automatically sent, if enabled, when a Channel Rate Alarm occurs and when it clears;
- Trap automatically sent, if enabled, when a channel is first present and when it is first absent; and
- Unit reset control.

NOTE: * When setting channel rates the total sum must not exceed the allowable 148 Mb rate. It may be necessary to enter the lower rate channels first depending on the existing overall sum.

[†] When a channel is disabled via SNMP, if ASI signal is present at this channel input to MMM-4681, front panel LED corresponding to disabled channel will flash. This gives visual indication that channel is disabled.

MMX-4681:

- The current state of the Urgent and Non Urgent Alarms;
- An indication of the presence of a valid STM-1 input;
- Information about each channel:
 - An indication that the channel input signal is present;
 - An indication whether the channel is enabled or not[‡]. Can be remotely set for enabled or not enabled[‡].
 - An indication of the packet size;
 - An indication of the approximate data rate;
 - A 15 byte maximum Alias (name) for the channel can be read and set;
- An indication of the jumper selected (SW4-4) configuration for the output – CMI, NRZ, or inverted NRZ;
- The software version of the main FPGA in the format 'x.y', where x is the major rev. no. and y the minor.
- Whether "Trap" functions are enabled;
- Trap automatically sent, if enabled, on Urgent and Non Urgent alarms occurring and when they clear;
- Trap automatically sent, if enabled, when a channel is first present and when it is first absent; and
- Unit reset control.

NOTE: [‡] When a channel is disabled via SNMP, if ASI signal is present at this channel within the STM-1 stream, front panel LED of MMX-4681 corresponding to disabled channel will flash. This gives visual indication that channel is disabled.

Maintenance & Storage

Maintenance:

No regular maintenance is required.

Care however should be taken to ensure that all connectors are kept clean and free from contamination of any kind. This is especially important in fibre optic equipment where cleanliness of optical connections is critical to performance.

Storage:

If the equipment is not to be used for an extended period, it is recommended the whole unit be placed in a sealed plastic bag to prevent dust contamination. In areas of high humidity a suitably sized bag of silica gel should be included to deter corrosion.

Where individual circuit cards are stored, they should be placed in antistatic bags. Proper antistatic procedures should be followed when inserting or removing cards from these bags.

Warranty & Service

Equipment is covered by a limited warranty period of three years from date of first delivery unless contrary conditions apply under a particular contract of supply. For situations when “**No Fault Found**” for repairs, a minimum charge of 1 hour’s labour, at IRT’s current labour charge rate, will apply, whether the equipment is within the warranty period or not.

Equipment warranty is limited to faults attributable to defects in original design or manufacture. Warranty on components shall be extended by IRT only to the extent obtainable from the component supplier.

Equipment return:

Before arranging service, ensure that the fault is in the unit to be serviced and not in associated equipment. If possible, confirm this by substitution.

Before returning equipment contact should be made with IRT or your local agent to determine whether the equipment can be serviced in the field or should be returned for repair.

The equipment should be properly packed for return observing antistatic procedures.

The following information should accompany the unit to be returned:

1. A fault report should be included indicating the nature of the fault
2. The operating conditions under which the fault initially occurred.
3. Any additional information, which may be of assistance in fault location and remedy.
4. A contact name and telephone and fax numbers.
5. Details of payment method for items not covered by warranty.
6. Full return address.
7. For situations when “**No Fault Found**” for repairs, a minimum charge of 1 hour’s labour will apply, whether the equipment is within the warranty period or not. Contact IRT for current hourly rate.

Please note that all freight charges are the responsibility of the customer.

The equipment should be returned **to the agent who originally supplied the equipment** or, where this is not possible, to IRT direct as follows.

Equipment Service
IRT Electronics Pty Ltd
26 Hotham Parade
ARTARMON
N.S.W. 2064
AUSTRALIA

Phone: 61 2 9439 3744
Email: service@irtelectronics.com

Fax: 61 2 9439 7439