

Handshake connection Type ZDA-3301RH 8, 34 & 45 Mb/s Data Amplifiers

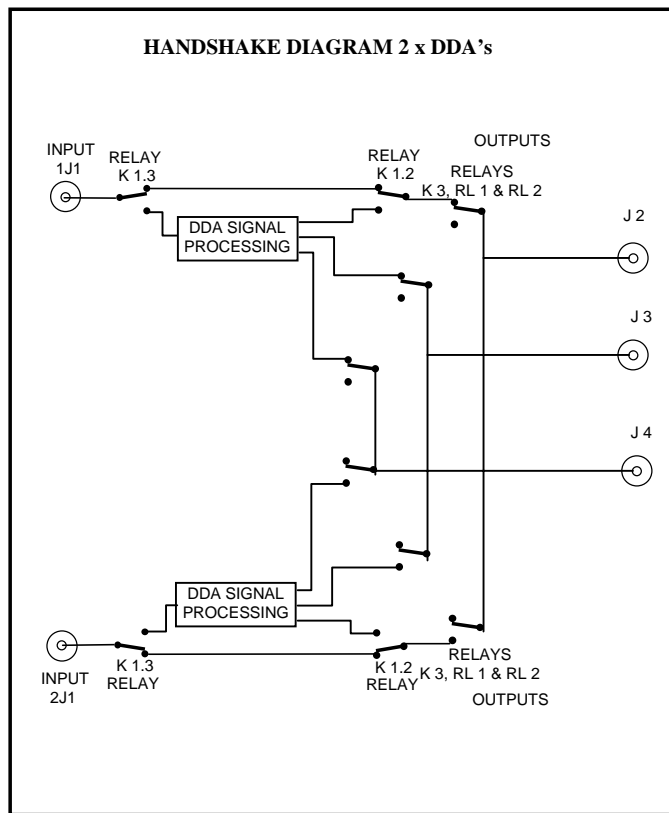

Features:

- **Redundant pair operation.**
- **Monitor & break access facility.**
- **Protection switching facility.**
- **External alarms from each module.**
- **One output bypass on power loss.**
- **Compatible with other IRT Eurocard modules and frames.**

General:

IRT produces a range of data distribution amplifiers that operate at the 8, 34 & 45 Mb/s rates in accordance with G.703. All incorporate a protection switching facility for the switching in of signals from a standby module when a fault is detected.

To facilitate this mode of operation, the ZDA-3301RH provides all of the required signal and logic interconnections between two modules.

The individual module alarms are also provided for remote monitoring purposes.

Three switched outputs are provided at the rear of the module with an additional output for monitoring purposes on each front panel. The primary output is controlled by relays to provide a bypass signal from the input during a power failure.

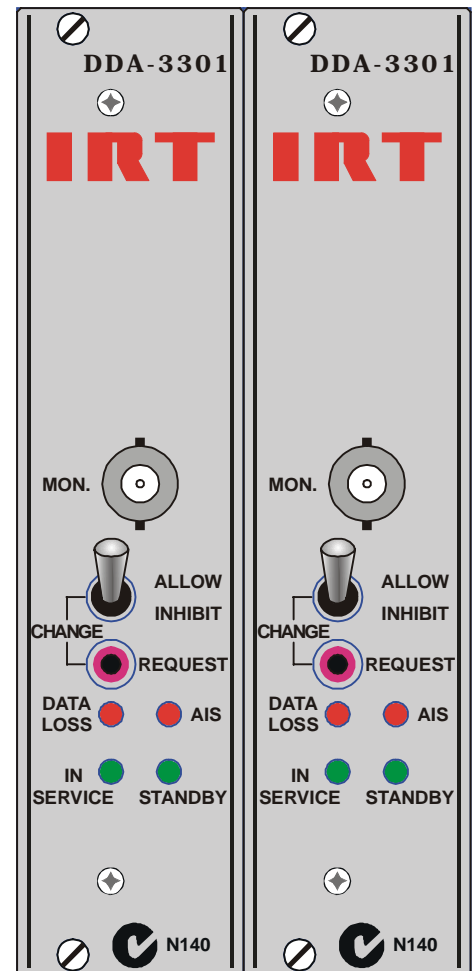

An Alarm Indication Signal (AIS) detected in the data stream generates a changeover request for a companion unit. In addition, the module may be forced into bypass mode by an external signal.

Changeover-inhibit and changeover-request switches are provided on the front panel for local manual control.

ZDA-3301RH Technical Specifications

Controls & alarms:

Input:

External Change-over Request A ground applied to this input will emulate the operation of the front panel switch "Change Request".

Outputs:

Bypass Contact closure to ground if power has failed.

General Alarm Contact closure to ground if:-
 a. Data Loss is detected OR
 b. AIS is detected AND the AIS disable link (LK 1) is not installed.

AIS detection is defined as at least 2048 consecutive data "1"s.

Data Loss is defined as less than 120 data "1"s in 512 34 Mbit clock periods.

In Service (Main) Path Indication Transistor switch to ground if card is active (if DA version is equipped).

Connectors:

Data:	BNC.
Alarm:	Krone LSA plus.
<i>In Service (Main)</i> Path:	Krone LSA plus.

Changeover logic:

A changeover to the companion module will occur under any of the following conditions:

- Loss of input signal
- AIS detection alarm (provided AIS is not disabled by link LK 1)
- Loss of power

In all of the above cases switching will only occur if:
 companion module is able to provide an output free of the same defects
 and
 changeover inhibit switch is not activated on either module.

Priority logic:

The priority switching in normal mode follows non reverting logic which dictates:

In the event of failure of main then standby DDA will assume control and become *Main* causing the failed path DDA to become *Standby*.

This implies that when the failed path is restored that it will remain as *Standby* and not become *Main* unless either a failure of *Main* occurs or a manual changeover is requested.

Power on reset.

When power is applied to the pair, the *power on reset* signal will set the module which was last enabled as *Main* as *Main* and the other module will be forced to act as *Reserve*.

When power is applied to a pair for the first time it may be necessary to force the desired module to become main by pressing the *Change Request* button on the front panel of the desired module. The *Main* module will be indicated by the *In Service* LED being lit on the front panel.

Due to our policy of continuing development, these specifications are subject to change without notice.

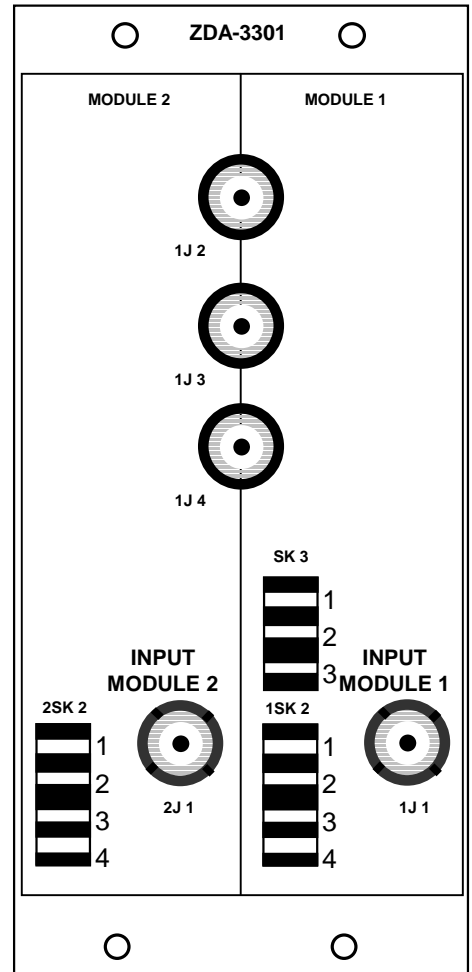

Detailed specifications available from:

Manufacturer:
IRT Electronics Pty Ltd
 26 Hotham Parade
 ARTARMON
 N.S.W. 2064 AUSTRALIA
 Phone: +61 2 9439 3744
 Fax: +61 2 9439 7439
 Email: sales@irtelectronics.com

Local Agent:

IRT can be found on the Internet at:
<http://www.irtelectronics.com>