

SDI / Composite Test Pattern Generator with Crash Switching Type DVG-4090

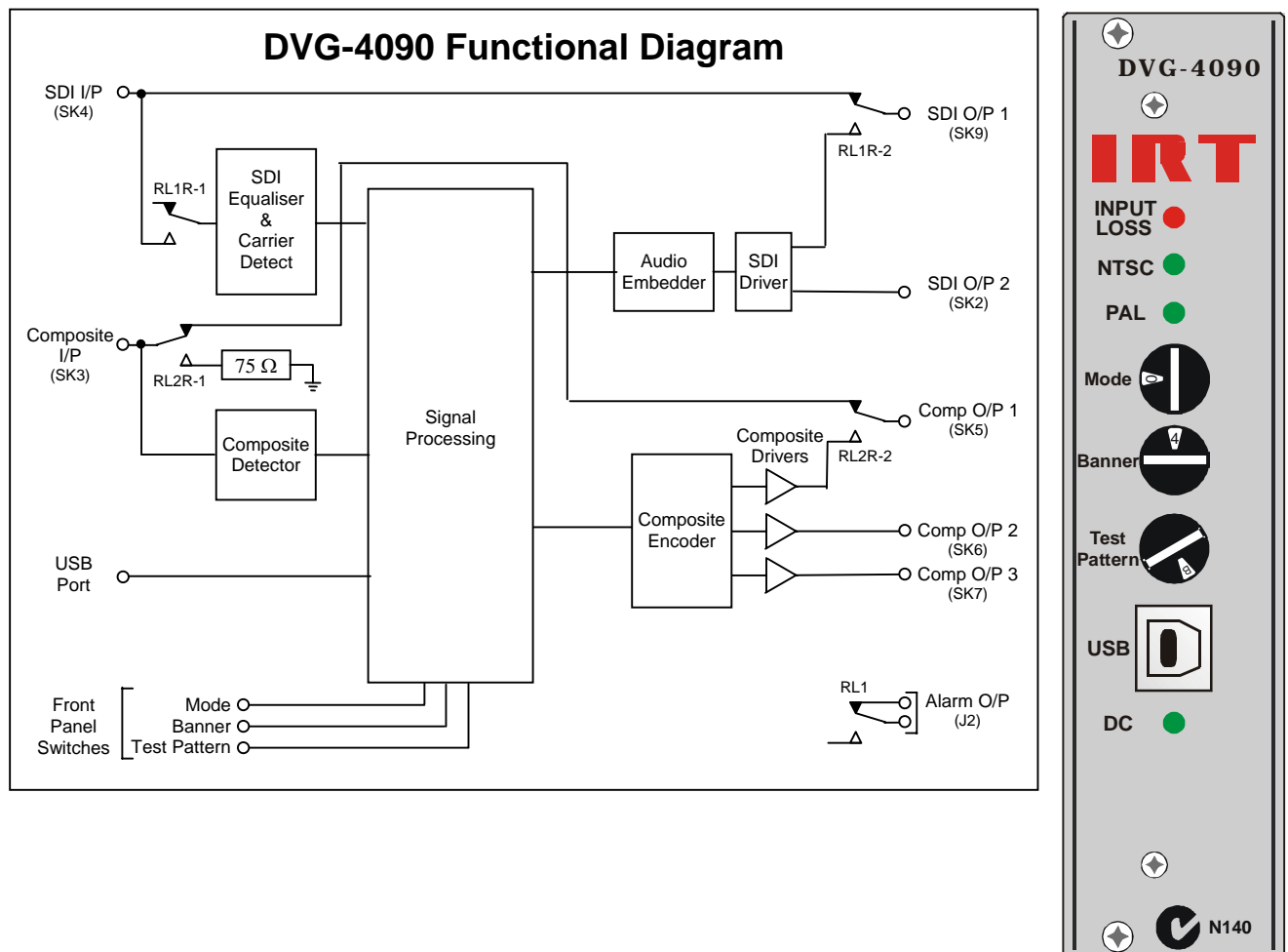

Features:

- SDI or Composite PAL/NTSC operation.
- Choice of 16 Test Patterns on loss of video input.
- Choice of 8 banners overlaid or keyed onto SDI input or Test Pattern output.

General:

The DVG-4090 acts as an analogue / digital video crash switcher and test pattern generator. On loss of video input, output is automatically switched to a choice of 16 test patterns.

8 custom built banners containing text or pictures, such as station logos, and 2 full screen pictures can be downloaded by supplied software. Single banners can be overlaid or keyed onto the test pattern output in the lower section of the video picture. In the case of an SDI input, these banners can also be overlaid onto the existing stream.

A countdown banner and audio test signal insertion is also available for link identification purposes.

The DVG-4090 is designed to fit IRT's standard Eurocard frames as well as IRT's 4000 series frame for use with IRT's SNMP system and may be used alongside any other of IRT's analogue or digital Eurocards.

DVG-4090 Technical Specifications

Input - Digital:

Connector 75Ω BNC.
 Format 270 Mbit/s SDI (SMPTE 259M), 625 or 525 line (link selectable).
 Equalisation Automatic, better than 200 metres at 270 Mb/s for Belden 8281 or equivalent cable.

Input - Analogue:

Connector 75Ω BNC.
 Format PAL or NTSC (link selectable).

Outputs - Digital:

Number 2 x SDI (one with relay bypass when used with SDI input), 625 or 525 line (link selectable);
 1 x SDI when used with analogue input link setting.
 Connectors 75Ω BNC.
 Format Re-clocked 270 Mbit/s SDI (SMPTE 259M).
 Signal Level 800 mV ±10%.

Outputs - Analogue:

Number 3 x Composite (one with relay bypass when used with analogue composite input), PAL or NTSC (link selectable).
 Connectors 75Ω BNC.

Alarm Output:

Closed relay contacts on loss of input signal.

Power requirements:

Power consumption 28 Vac CT (14-0-14) or ± 16 Vdc.
 <4 VA.

Other:

Temperature range 0 - 50° C ambient
 Mechanical Suitable for mounting in IRT 19" rack chassis with input output and power connections on the rear panel
 Finish: Front panel Grey background, silk-screened black lettering & red IRT logo
 Rear assembly Detachable silk-screened PCB with direct mount connectors to Eurocard and external signals
 Dimensions 32 mm x 3 U x 220 mm IRT Eurocard
 Standard accessories Digital and Analogue Rear connector assemblies.

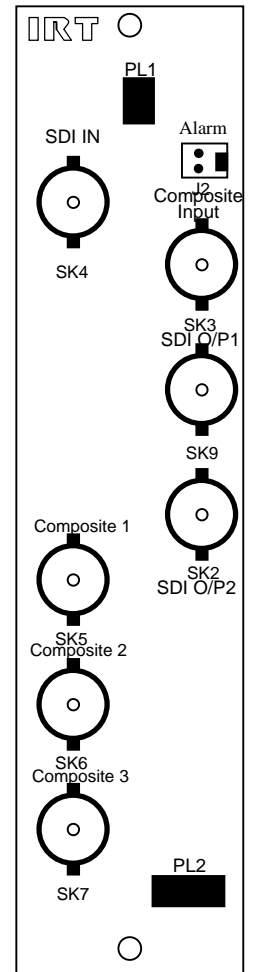

Due to our policy of continuing development, these specifications are subject to change without notice.

Detailed specifications available from:

Manufacturer:
IRT Electronics Pty Ltd
 26 Hotham Parade
 ARTARMON
 N.S.W. 2064 AUSTRALIA
 Phone: +61 2 9439 3744
 Fax: +61 2 9439 7439
 Email: sales@irtelectronics.com

Local Agent:

IRT can be found on the Internet at:
<http://www.irtelectronics.com>